



32Classic

Manual / User Guide



www.harrisonaudio.com



Nashville - Music City USA

Visit Harrison Audio LLC at:
www.harrisonaudio.com

Harrison Audio LLC

All rights reserved.

All other product names and trademarks are the property of their respective owners and are hereby acknowledged.

No part of this publication may be reproduced in any form or by any means, whether mechanical or electronic, without the written permission of Harrison Audio LLC, 750 Jim Parker Drive STE 103, Smyrna TN. 37167 USA

As research and development is a continual process, Harrison Audio LLC reserves the right to change the features and specifications described herein without notice or obligation.

Harrison Audio LLC cannot be held responsible for any loss or damage arising directly or indirectly from any error or omission in this manual.

PLEASE READ ALL INSTRUCTIONS, PAY SPECIAL HEED TO SAFETY WARNINGS.

May 2024

Version v3.0

TABLE OF CONTENTS

1.0	INTRODUCTION	8
1.1	FEATURES	9
2.0	MODULE DESCRIPTIONS	11
2.1	INPUT CHANNELS	11
2.1.1	Input Section Controls	13
2.1.1.1	Return Input	13
2.1.1.2	Inline Switch	13
2.1.1.3	Mic Trim	14
2.1.1.4	48V Switch	14
2.1.1.5	-20 Switch	14
2.1.1.6	Phase Switch	14
2.1.1.7	Line Input, Trim Control and Trim Select	14
2.1.1.8	INST Switch	14
2.1.1.9	Playback Switch	14
2.1.1.10	Line Input Summing	15
2.1.1.11	Input Signal Activity/Clip Indicator	15
2.1.1.12	INS Switch	15
2.1.2	Aux Send Section	15
2.1.2.1	Aux Send controls	15
2.1.2.2	Stereo Aux Playback Feature	16
2.1.3	EQ Section	17
2.1.3.1	Hi EQ	18
2.1.3.2	Hi Mid EQ	18
2.1.3.3	Lo Mid EQ	18
2.1.3.4	Lo EQ	18
2.1.3.5	High Pass and Low Pass Filters	19
2.1.4	Bus Routing Section	19
2.1.4.1	Bus Assign	19
2.1.4.2	Stereo Bus Assign	20
2.1.4.3	SOLO Button	20
2.1.4.4	0 dB Lock Button	21
2.1.4.5	Monitor Inline Mode	21
2.1.5	Fader Section	21
2.1.5.1	Mute Button	21
2.1.5.2	Channel Fader	21
2.1.5.3	LED Level Meter	21
2.2	MIX BUS MASTERS	23
2.2.1	Mix Bus Masters 1-2, 3-4, 5-6 with Cue/Matrix Master	23
2.2.1.1	Mix Bus Master Section	25
2.2.1.1.1	Mix Bus Fader and 0 dB Lock Button	25
2.2.1.1.2	Mute Button	25
2.2.1.1.3	Solo Button	25
2.2.1.1.4	INS Button	25
2.2.1.1.5	Main Mix Assign Button and Pan Control	25
2.2.1.1.6	LED Level Meter	27

2.2.1.2	Cue/Matrix Output Section	27
2.2.1.2.1	Cue/Matrix Level Control and Mute	27
2.2.1.2.2	Dante Button	27
2.2.1.2.3	Return Mix Button and Level	27
2.2.1.2.4	Aux Mix Buttons and Level controls	27
2.2.1.2.5	Mix Bus and Main Stereo Mix Assign Buttons	29
2.2.1.2.6	EXT1 and EXT2 Assign Buttons	29
2.2.1.2.7	Source Summing	29
2.2.1.2.8	Solo Button	29
2.2.1.2.9	Talk Button	29
2.2.2	Mix Bus Master 7-8 With Aux Master/Return Master	29
2.2.2.1	Mix Bus Master Section	31
2.2.2.1.1	Mix Bus Fader and 0 dB Lock Button	31
2.2.2.1.2	Mute Button	31
2.2.2.1.3	Solo Button	31
2.2.2.1.4	INS Button	31
2.2.2.1.5	Main Mix Assign Button and Pan Control	31
2.2.2.1.6	LED Level Meter	31
2.2.2.2	Return Master Section	33
2.2.2.2.1	Return Bus Master Level Control and Mute	33
2.2.2.2.2	Main Stereo Mix Assign Button	33
2.2.2.2.3	Solo Button	33
2.2.2.2.4	Signal Indicator LEDs	34
2.2.2.3	Aux Master Section	34
2.2.2.3.1	Aux Master Level Controls	35
2.2.2.3.2	Aux Master Solo Buttons	35
2.2.2.3.3	Main Stereo Mix Assign Button	35
2.2.2.3.4	Stereo Aux Mute Button	35
2.2.2.4	Talkback Section	35
2.3	MASTER MODULE	36
2.3.1	Meter Mode/Dante Status	38
2.3.1.1	Dante Status	38
2.3.1.2	LED Meter Controls	38
2.3.2	Mic/Instrument Input	39
2.3.2.1	MIC Switch	39
2.3.2.2	-20 Switch	39
2.3.2.3	48V Switch	40
2.3.2.4	Gain Control	40
2.3.2.5	MAIN MIX Switch	40
2.3.3	Main Mix Modes Section	40
2.3.3.1	INS Button	40
2.3.3.2	Main Stereo Mix Fader and 0 dB Lock Button	41
2.3.3.3	Main Mix Output Transformer Option	42
2.3.4	Monitor Source Selection	42
2.3.4.1	Dante Source	43
2.3.4.2	EXT 1 and EXT2 Monitor Inputs	43
2.3.4.3	Main Mix Source	43
2.3.4.4	Surround Source	43
2.3.4.5	Monitor Source Summing	43

2.3.4.6	SOLO LED	43
2.3.4.7	Alternate Monitor Output and Level Control	44
2.3.4.8	DIM Button and Control	44
2.3.4.9	Headphone Volume Control	44
2.3.4.10	MONO Button	44
2.3.4.11	Left and Right MUTE buttons	44
2.3.5	Monitor Level Control	44
3.0	CONSOLE I/O CONNECTIONS	46
3.1	I/O CONNECTIONS PHILOSOPHY	46
3.2	INPUT CHANNEL STRIP CONNECTIONS	47
3.2.1	Channel Strip DB25 Connectors	48
3.2.2	Channel Strip DB25 Connector Pinouts	50
3.3	GROUP/MASTER/MONITOR SECTION CONNECTIONS	51
3.3.1	Master Section DB25 Connectors	52
3.3.2	Master Section DB25 Connector Pinouts	54
3.3.2.1	Surround 9-12 Inputs and Outputs	54
3.4	DANTE INTERFACE CONNECTIONS	58
3.4.1	Overview	58
3.4.2	Analog Connections to Converters and Dante	58
3.4.3	Converter/Dante Interface Cards	60
3.4.4	Dante Wordclock	62
3.4.5	Dante Channel Assignments	63
4.0	FUNCTIONAL DESCRIPTION AND SIGNAL FLOW	66
4.1	CHANNEL STRIP BLOCK DIAGRAM	66
4.1.1	Channel Strip Signal Flow – Mixdown Mode	68
4.1.2	Channel Strip Signal Flow – Monitor Inline Mode	68
4.1.3	Return Mix	69
4.2	BUS MODULE 1-6 BLOCK DIAGRAM	69
4.2.1	Group Bus Section	70
4.2.2	Cue/Matrix Section	71
4.2.3	Talkback	71
4.3	BUS MODULE 7-8 BLOCK DIAGRAM	71
4.3.1	Group Bus Section	73
4.3.2	Aux and Return Mix Master Sections	73
4.3.3	Talkback	73
4.4	MASTER MODULE BLOCK DIAGRAM	74
4.4.1	Main Stereo Mix Section	74
4.4.2	Instrument/Mic Input Section	74
4.4.3	Monitor Section	75
4.4.3.1	External Monitoring	76
4.4.3.2	Surround Monitoring	76
4.4.3.3	Alternate Monitor Output	78
5.0	SOLO OPERATION	79
5.1	SOLO IN THE CHANNEL STRIP MODULES	79
5.2	SOLO IN THE GROUP/CUE-MATRIX MODULES	80
5.3	SOLO IN THE GROUP/AUX- MASTER MODULE	80
5.4	SOLO IN THE MASTER MODULE	82
6.0	MONITOR INLINE MODE	83
6.1	THE CHANNEL STRIP IN MONITOR INLINE MODE	83

7.0	MIXDOWN WITH HIGH CHANNEL COUNT	84
7.1	96 CHANNEL MIX / MIXDOWN MODE	85
7.2	96 CHANNEL MIX / MONITOR INLINE MODE	86
8.0	SPECIFICATIONS	88
9.0	SAFETY NOTICES	91
10.0	Patch Bay Examples (Patch Bays NOT Included)	95

LIST OF FIGURES

FIGURE 1: 32CLASSIC OVERVIEW.....	9
FIGURE 2: INPUT CHANNEL STRIP.....	12
FIGURE 3: CHANNEL STRIP INPUT SELECT.....	13
FIGURE 4: CHANNEL STRIP AUX SEND SECTION.....	16
FIGURE 5: CHANNEL STRIP EQ SECTION.....	17
FIGURE 6: CHANNEL STRIP BUS ROUTING SECTION.....	20
FIGURE 7: CHANNEL STRIP FADER SECTION.....	22
FIGURE 8: MIX BUS MASTERS 1-2, 3-4, 5-6 WITH CUE/MATRIX.....	24
FIGURE 9: MIX BUS MASTER SECTION ON BUS 1-2, 3-4, 5-6.....	26
FIGURE 10: MIX BUS CUE/MATRIX SECTION.....	28
FIGURE 11: MIX BUS MASTER 7-8 WITH AUX MASTER/RETURN MASTER.....	30
FIGURE 12: MIX BUS MASTER SECTION ON BUS 7-8.....	32
FIGURE 13: RETURN BUS MASTER.....	33
FIGURE 14: BUS STRIP 7-8 AUX MASTER SECTION.....	34
FIGURE 15: BUS STRIP 7-8 TALKBACK SECTION.....	36
FIGURE 16: 32CLASSIC MASTER MODULE.....	37
FIGURE 17: METER MODE/DANTE STATUS SECTION.....	38
FIGURE 18: INSTRUMENT INPUT.....	39
FIGURE 19: MAIN MIX MODES SECTION.....	40
FIGURE 20: MAIN MIX FADER SECTION.....	41
FIGURE 21: MONITOR SOURCE CONTROLS.....	42
FIGURE 22: MONITOR LEVEL CONTROL.....	45
FIGURE 23: TASCAM/AES59 STANDARD ANALOG DB25 CONNECTOR PINOUT.....	46
FIGURE 24: CHANNEL STRIP CONNECTORS VIEWED FROM UNDERSIDE OF CONSOLE.....	48
FIGURE 25: CHANNEL STRIP I/O CONNECTORS.....	49
FIGURE 26: CHANNEL MOTHERBOARD CONNECTOR PINOUTS.....	50
FIGURE 27: MASTER SECTION CONNECTORS VIEWED FROM UNDERSIDE OF CONSOLE.....	52
FIGURE 28: MASTER SECTION I/O CONNECTORS.....	53
FIGURE 29: MASTER MOTHERBOARD CONNECTOR PINOUTS - 1.....	55
FIGURE 30: MASTER MOTHERBOARD CONNECTOR PINOUTS – 2.....	56
FIGURE 31: MASTER MOTHERBOARD CONNECTOR PINOUTS – 3.....	57
FIGURE 32: CONNECTIONS TO CONVERTER/DANTE CARDS.....	59
FIGURE 33: CONVERTER/DANTE CARD BLOCK DIAGRAM.....	60
FIGURE 34: NETWORK INTERCONNECTION OF CONVERTER/DANTE CARDS.....	61
FIGURE 35: DANTE WORDCLOCK SETUP- EXTERNAL CLOCK.....	63
FIGURE 36: DANTE WORDCLOCK SETUP- INTERNAL CLOCK.....	63
FIGURE 37: CHANNEL STRIP BLOCK DIAGRAM.....	67
FIGURE 38: CHANNEL STRIP SIGNAL FLOW - MIXDOWN MODE.....	68
FIGURE 39: CHANNEL STRIP SIGNAL FLOW – MONITOR INLINE MODE.....	69
FIGURE 40: BUS MODULE 1-6 BLOCK DIAGRAM.....	70
FIGURE 41: BUS MODULE 7-8 BLOCK DIAGRAM.....	72
FIGURE 42: MASTER MODULE BLOCK DIAGRAM.....	75
FIGURE 43: MONITOR SIGNAL FLOW IN SURROUND MODE.....	77
FIGURE 44: CHANNEL STRIP SOLO.....	79
FIGURE 45: GROUP 1-6 SOLO.....	80
FIGURE 46: GROUP 7-8 SOLO.....	81

FIGURE 47: MASTER MODULE SOLO..... 82
FIGURE 48: CHANNEL STRIP IN MONITOR INLINE MODE 83
FIGURE 49: RETURN AND STEREO AUX MASTERS MIX ROUTING 84
FIGURE 50: 96 INPUT MIXDOWN - METHOD 1..... 85
FIGURE 51: 96 INPUT MIXDOWN - METHOD 2..... 86
FIGURE 52: 96 INPUT MIXDOWN - METHOD 3..... 87

LIST OF TABLES

TABLE 1: STANDARD DANTE CHANNEL ASSIGNMENTS 64
TABLE 2: STANDARD DANTE MASTER SECTION ASSIGNMENTS 65
TABLE 3: TYPICAL SURROUND MONITOR ASSIGNMENTS 77

Harrison 32Classic Analog Studio Console

1.0 Introduction

The Harrison 32Classic is a new generation analog mixing console designed specifically for the DAW-based recording studio.

The 32Classic is based on Harrison circuit designs originally used in our renowned 32C console in the late 1970's but is built with modern state of the art components giving better performance and improved long-term reliability. The classic analog sound like that of the original 32C is presented in a modern console offering several advanced and DAW-optimized features not seen on any classic analog consoles.

Unique among analog consoles is fully integrated DAW support featuring onboard professional grade A/D and D/A converters along with Dante network interfacing. Dante networking replaces the traditional tape recorder interfacing of classic analog consoles with a single ethernet cable to a computer running your favorite DAW software. Connection flexibility is provided by also permitting analog interfacing to external recorders or other equipment, and even a mixed analog/Dante installation is easily accommodated.

The 32Classic is a fully modular console offering 32 mono input channels, 8 mono mix buses (capable of functioning as 4 stereo groups) plus a main stereo mix, 4 mono auxiliaries and one stereo auxiliary. An additional line-level "Return" input on each input channel feeds a separate stereo mix which may be selected to sum into the main stereo mix or also feed the Cue/Matrix outputs. Used in conjunction with the "monitor inline" input channel mode, as many as 96 inputs are possible on mixdown. The 3 stereo Cue/Matrix outputs may be used to create headphone or monitor mixes. Each of these 3 mixes may be built from any combination of the main stereo mix, mix bus pairs, mono and stereo aux mixes, a L/R pair of inputs from the Dante interface, 2 external stereo analog sources and the Return mix. A comprehensive monitoring section with 11.1 or 7.1.4 surround playback capability is provided for feeding control room monitors and headphones, as well as a talkback facility with built-in microphone.

Another unique feature is a front panel mic/instrument input which may be selected as an input source to any input channel. This feature is very useful for making last minute overdubs or quick voiceovers in the control room, right at the console.

Each input channel, mix bus and the main stereo output feature a 20 segment LED meter. The console meter bridge features LED-illuminated analog meters for all main bus, cue, and monitor outputs.

The 32Classic frame is designed to facilitate use with DAWs. The full-length front armrest is deep enough to accommodate DAW and music keyboards, and a mouse or trackball with room to spare. The top of the console is flat with ample room for multiple video monitors and nearfield monitor speakers. A clean installation is ensured by having all power, network and audio wiring hidden in the console legs.

Figure 1 shows one possible way the console may look with a DAW setup.

Figure 1: 32CLASSIC OVERVIEW

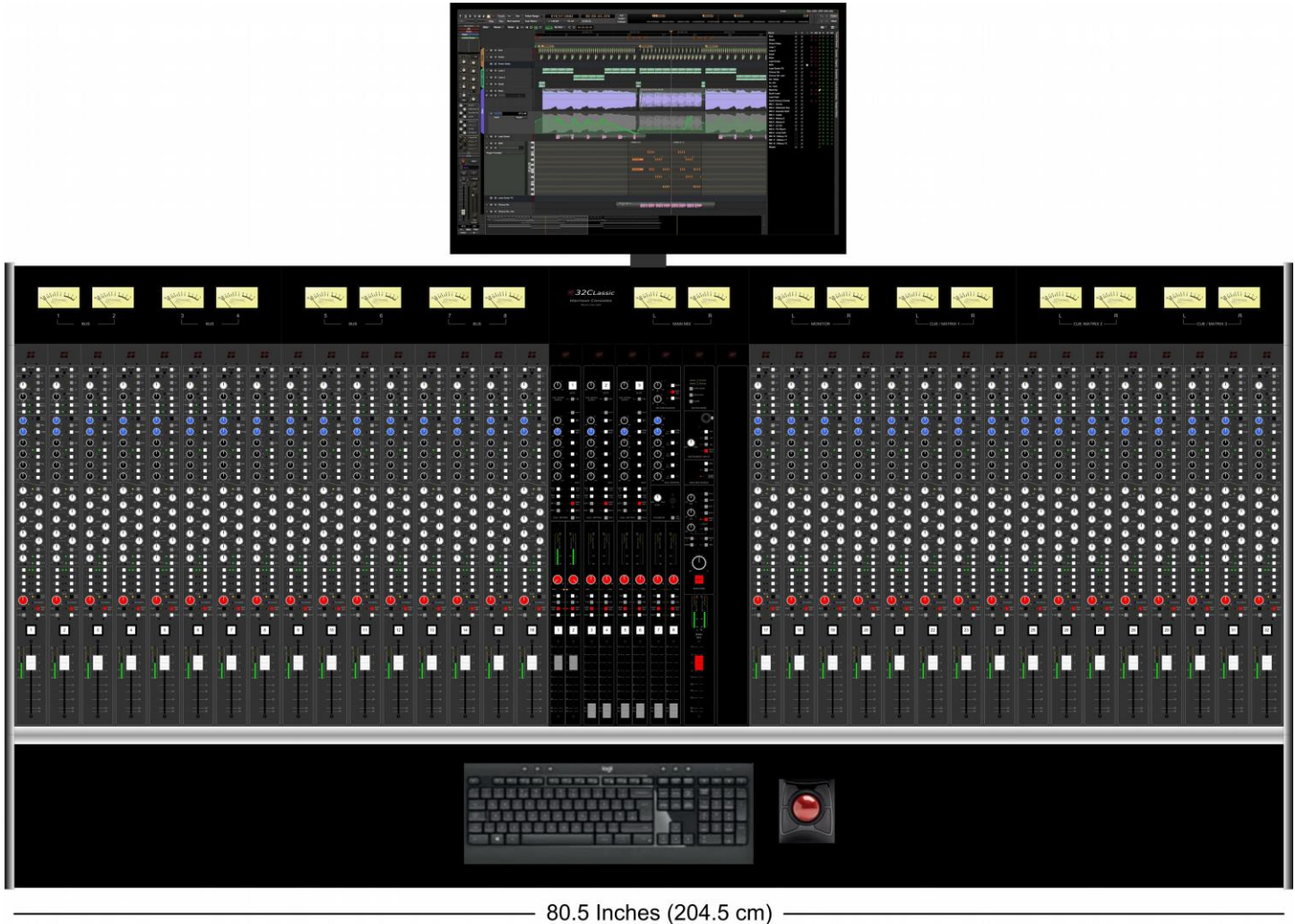

1.1 Features

The 32Classic console offers many features familiar to users of analog recording consoles, but also provides several new and innovative additions.

- optimized for DAW users
 - built-in professional grade A/D and D/A converters
 - Dante networking, up to 64x64 channels at 96 KHz
 - DAW compatible frame design, featuring a 2-tiered front bolster for computer mouse and computer (or music) keyboard
 - generously sized flat top panel for video and audio monitors

- robust aluminum frame with large integrated cable raceways
- clean profile with all audio, power and network wiring concealed in the legs if desired
- ALL analog audio inputs and outputs fully balanced on standard DB25 connectors with Tascam/AES59 standard pinout, including inserts, line inputs and channel direct outputs
- Jensen transformer balancing on microphone inputs and main stereo bus output
- rugged construction utilizing surface mount components on gold plated glass-epoxy printed circuit boards
- rigid bus/backplane on printed circuit boards – no ribbon cables
- premium long-life conductive plastic potentiometers
- top quality faders with wide 15mm caps for precision feel and control
- all electronic wear-proof audio switching and routing throughout
- classic Harrison 32C 4-band EQ and filters on each channel strip
- monitor inline channel strip architecture providing tracking/mixdown modes with capability of up to 96 inputs on mixdown
- front panel mic/instrument input assignable to any input channel
- LED indicator on every pushbutton switch
- 8 mono mix buses arranged in pairs with insert points on all 8 mix buses
- stereo main mix bus with insert points
- 3 foldback/cue/matrix buses and outputs
- 4 mono AUX buses
- 1 stereo AUX bus
- stereo solo bus
- 0 dB lock button on all faders
- multiple external monitor inputs
- main monitor outputs (11.1 or 7.1.4 surround capable)
- separate nearfield monitor output
- large meter bridge with LED illuminated analog meters
- external high-performance PSU

2.0 Module Descriptions

The following sections will give overviews of the console modules and the controls on each. More detailed descriptions of the console signal flow, and operation will be presented in Chapter [4.0](#).

2.1 Input Channels

The input channels feature separate mic and line inputs (with independent trim controls), 4-band EQ and HP/LP filters, the usual phantom/phase/pad selectors, and flexible input selection. Input to the channel strip may be selected from the mic or line inputs, playback from the Dante interface or the mic/instrument input located in the master section. The microphone input is transformer balanced with a Jensen transformer as standard.

A selectable monitor in-line Record mode is provided which splits the channel flow to permit playback monitoring from the Dante interface to the main buses while recording. In this mode the selected input passes through the EQ section and then feeds the aux buses and the recorder via the direct and Dante interface outputs. Playback from the Dante interface feeds the channel fader and routing section. See Section [6.0](#) for detailed information of the Inline mode of operation.

The bus routing section provides individual mix bus assigns and selectable pan control. Bus panning and main stereo mix panning are separately enabled. A 20 LED signal meter is situated beside the fader.

[Figure 2](#) shows the layout of the channel strip.

The input channel strip features a comprehensive set of controls. Their functions will be outlined in the following sections. Refer to [Figure 2](#) for the locations of these controls.

Figure 2: INPUT CHANNEL STRIP

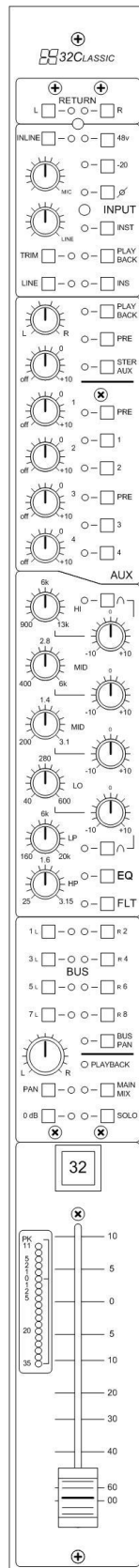

2.1.1 Input Section Controls

The input section selects the return and main inputs to the channel strip. These controls are shown in [Figure 3](#).

2.1.1.1 Return Input

The Return input is a second line level input to the channel strip which feeds a separate stereo Return mix. While located with the input channel, the signal from this input appears nowhere else on the input channel strip. The master controls for the stereo mix fed by this input are at the top of the Mix Bus 7-8 module. At the top of the channel strip are 2 buttons which route the Return input to the left and right sides of this Return mix. LEDs indicate that the return input is assigned to either or both sides of the Return mix.

Below the assign LEDs is a large bi-color signal-present LED indicating activity and clipping on the Return input.

2.1.1.2 Inline Switch

This switch puts the channel strip into the monitor inline mode. An unmistakable blue LED indicates the channel strip is in this mode. See [Section 6.0](#) for details of Monitor Inline mode operation.

Figure 3: CHANNEL STRIP INPUT SELECT

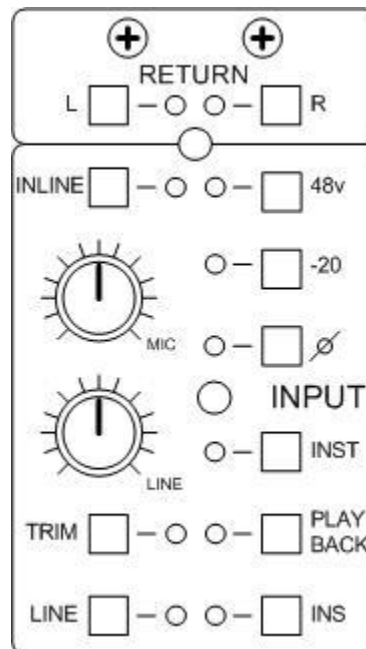

2.1.1.3 Mic Trim

This rotary control sets the gain of the microphone input. The gain range is +20 to +70 dB un-padded.

2.1.1.4 48V Switch

This button provides 48V phantom power to the microphone input.

2.1.1.5 –20 Switch

This button inserts a 20 dB pad at the microphone input ahead of the input gain stage.

2.1.1.6 Phase Switch

This button reverses the polarity of the channel strip input source. See the next 3 sections and Section [4.1](#) for descriptions of the channel strip input select operation.

2.1.1.7 Line Input, Trim Control and Trim Select

The Line button deselects the channel strip microphone input and selects the line input as the input source. Nominally this input is +4 dBu referenced, however if additional gain is required pressing the TRIM button will enable the Line Trim control. The Line Trim control has an adjustment range of –6 dB to +6 dB.

2.1.1.8 INST Switch

This button deselects the channel strip microphone input and selects the Mic/Instrument input on the stereo master module to be the input to the channel strip. The gain/trim control for this input is at the input connector, in the master section. See Section [2.3.2](#) for details. Additional gain/trim is possible with the Line trim knob if the Trim button is selected.

2.1.1.9 Playback Switch

This button deselects the channel strip microphone input and selects playback from the Dante interface as the input source. Trim control is possible with the Line trim knob if the Trim button is selected.

2.1.1.10 Line Input Summing

If any of the Line, Playback or Instrument buttons are selected the channel microphone input is deselected and the channel strip source becomes the selected input. If any combination of the Line, Playback and Instrument buttons are selected simultaneously, the selected sources will be summed together. If the Trim button is selected, overall gain trim over the summed inputs is provided by the Line Trim knob. The Phase button flips the polarity of the overall channel strip source signal, however set up.

2.1.1.11 Input Signal Activity/Clip Indicator

Between the Phase and Instrument button LEDs is a large bi-color signal-present LED indicating activity and clipping of the channel source. As noted above the channel source could be the sum of any combination of the Line, Playback and Instrument inputs if so selected.

2.1.1.12 INS Switch

The INS button enables the channel insert point. The insert is situated after the input selector, ahead of the EQ section in both record and mixdown modes. Insert send and return connections are on DB25 connectors (see Section [3.2.1](#)). Unlike other consoles where the insert connections are on jacks, engaging the INS button with no external equipment connected will result in no signal. The LED indicator associated with this button will show when the insert is engaged.

2.1.2 Aux Send Section

There are 4 mono aux sends and one stereo aux send. These controls are shown in [Figure 4](#).

2.1.2.1 Aux Send controls

The 5 Aux buses are designed to provide considerable flexibility when tracking or mixing. The Aux buses are fed with the selected channel input, post-EQ and selectable pre or post channel fader.

Each Aux bus send has the following:

- an assign button enabling channel send to the respective Aux bus
- level control
 - the Stereo Aux send also has a pan control
- PRE/POST (channel fader) select switch
 - The Stereo Aux has its own PRE/POST select
 - the mono Auxes are selected PRE/POST fader in pairs

When the channel strip is in monitor inline mode, the aux buses are fed post-EQ and pre fader only, since in this mode the channel fader is in the monitor path not the input path (see Section [6.0](#)).

Figure 4: CHANNEL STRIP AUX SEND SECTION

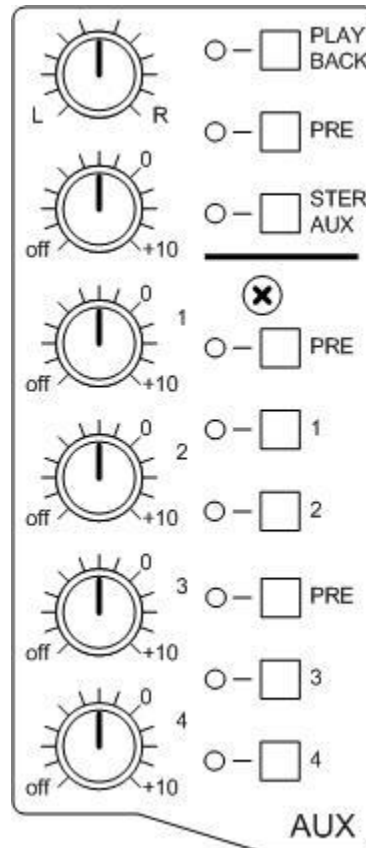

2.1.2.2 Stereo Aux Playback Feature

The stereo Aux bus can also be fed with the track playback from the Dante interface, and has its own Playback selection button (this is NOT the same Playback button as in the input source select, but it accesses the SAME input signal from the Dante interface). When the Stereo Aux send Playback button is engaged, the playback from the Dante interface is summed into the stereo aux along with the channel strip input, IF it is assigned.

- The stereo Aux level and pan controls come after this local summing, so also function on the playback source.
- The playback from the Dante interface is from the same Dante channel that feeds the Input selector

2.1.3 EQ Section

The 4-band EQ is based on the EQ section of the original Harrison 32C console and is shown in [Figure 5](#). In the original 32C console the EQ section was renowned for its sound and its precision. This comes from the proportional-Q design of the "bell" responses, and the generous overlap of the 4 frequency bands. This design is retained completely in the 32Classic EQ section.

The EQ section is placed into the signal path with the EQ button.

The EQ section also includes the 32C's high pass and low pass filters each with sweepable corner frequency. These come after the 4-band EQ in the signal path and can be enabled separately from the 4-band EQ with the FLT button.

Figure 5: CHANNEL STRIP EQ SECTION

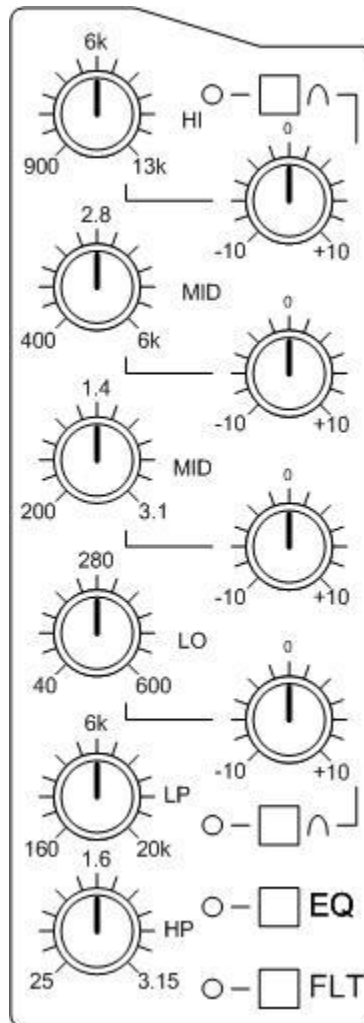

2.1.3.1 Hi EQ

The Hi EQ section provides a 6 dB/octave shelving response with corner frequency and boost/cut on separate knobs.

- corner frequency range: 900 Hz – 13 kHz
- boost/cut range: +/-10 dB

The bell button changes the response from shelving mode to a second-order bell response with the classic Harrison proportional-Q feature. The frequency knob now controls the center frequency of the response. The boost/cut range remains +/-10 dB.

2.1.3.2 Hi Mid EQ

The Hi Mid EQ section provides a second-order bell response with the classic Harrison proportional-Q feature. Center frequency and boost/cut are adjustable on separate knobs.

- center frequency range: 400 Hz – 6 kHz
- boost/cut range: +/-10 dB

2.1.3.3 Lo Mid EQ

The Lo Mid EQ section provides a second-order bell response with the classic Harrison proportional-Q feature. Center frequency and boost/cut are adjustable on separate knobs.

- center frequency range: 200 Hz – 3.1 kHz
- boost/cut range: +/-10 dB

2.1.3.4 Lo EQ

The Lo EQ section provides a 6 dB/octave shelving response with corner frequency and boost/cut on separate knobs.

- corner frequency range: 40 Hz – 600 Hz
- boost/cut range: +/-10 dB

The bell button changes the response from shelving mode to a second-order bell response with the classic Harrison proportional-Q feature. The frequency knob now controls the center frequency of the response. The boost/cut range remains +/-10 dB.

2.1.3.5 High Pass and Low Pass Filters

The classic 32C filters are switched into the signal path with the FLT button. They come after the 4-band EQ in the signal path.

These filters have 12dB/octave slope with the 3 dB corner frequencies adjustable by their respective knobs.

- High Pass Filter:
 - corner frequency range 25 Hz – 3.1 KHz
- Low Pass Filter:
 - corner frequency range 160 Hz – 20 KHz

Note that the frequency ranges of the filters overlap considerably, as on our original 32C console. It is thus possible to adjust the controls such that no signal passes through. Control room pranksters have been delighted by this feature for more than 4 decades.

2.1.4 Bus Routing Section

The Routing section assigns the post-fader channel output to the 8 sub buses and the main stereo mix. These controls are shown in [Figure 6](#).

2.1.4.1 Bus Assign

The 8 bus assign switches route the channel output to the 8 mix buses individually. A LED indicator beside each button indicates routing to that bus.

Panning between odd and even buses with the Pan knob is enabled with the Bus Pan button. This pan enable is independent of the pan enable to the main stereo mix. This is useful for example when it is desired to have the mix bus assign level remain at nominal when the pan control is used for panning into the main stereo mix.

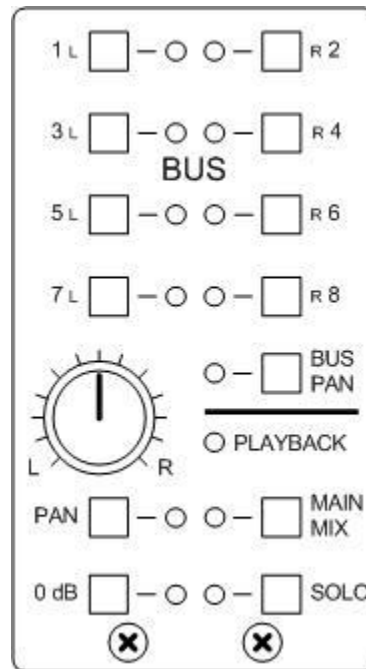
Figure 6: CHANNEL STRIP BUS ROUTING SECTION

2.1.4.2 Stereo Bus Assign

The channel output is assigned to the main stereo bus with the red Main Mix button. Panning between main mix left and right with the Pan knob is enabled with the Pan button. Note that this pan enable is independent of pan enable to the mix buses, however they both follow the pan knob position.

2.1.4.3 SOLO Button

The SOLO button solos the channel post-fader post-pan signal. The soloing point differs depending on whether the main stereo mix bus is routed:

- if the channel is routed to the main stereo mix bus (red Main Mix button engaged), the solo is taken post-fader and post-pan from the Main Mix path if the PAN button (for the Main Mix) is engaged. If the PAN button is not engaged the channel signal will be applied equally to left and right sides of the stereo solo bus.
- if the channel is not routed to the main stereo mix bus (red Main Mix button NOT engaged), the solo is taken post-fader and post-pan from the mix buses feed if the BUS PAN button (for the 8 mix buses) is engaged. If the BUS PAN button is not engaged the channel signal will be applied equally to left and right sides of the stereo solo bus.

The Solo operation described is arranged based on the expected operation of the console. Typically a stereo mix will be created on either pairs of mix buses or the main stereo mix, but seldom to both at the same time. Therefore to hear a solo as panned in stereo the soloing point changes to reflect which bus path is in use, giving priority to the main stereo mix.

2.1.4.4 0 dB Lock Button

The 0 dB Lock button is used to disable the fader ensuring the channel output is always at the 0 dB nominal level regardless of the fader position.

2.1.4.5 Monitor Inline Mode

The 8 mono mix buses and the main stereo mix are always fed post-fader, however the signal to the fader is different in mixing and record (monitor inline) modes.

In mix mode the fader is fed with the output of the EQ, which is always fed by the selected channel input signal. In record (monitor inline) mode the fader is fed the playback signal from the Dante interface. An unmistakable blue LED labelled PLAYBACK beside the PAN knob indicates that the fader and routing section are being fed by the playback signal.

Further details about the record (monitor inline) mode are presented in Section [6.0](#).

2.1.5 Fader Section

The Fader section of the channel strip is shown in [Figure 7](#).

2.1.5.1 Mute Button

The large, illuminated mute button mutes all outputs from the channel strip when engaged. It is labelled with the channel number.

2.1.5.2 Channel Fader

A high quality 100mm fader adjusts the channel output level to the mix buses, main stereo mix and Aux buses (if selected post fader).

2.1.5.3 LED Level Meter

The 20 segment LED meter indicates the channel strip level over the range -35 dBu to $+14$ dBu. In mixdown mode the meter indicates the signal level after the channel input selector, pre-insert. In Record (monitor in-line) mode the meter indicates the playback signal level.

Figure 7: CHANNEL STRIP FADER SECTION

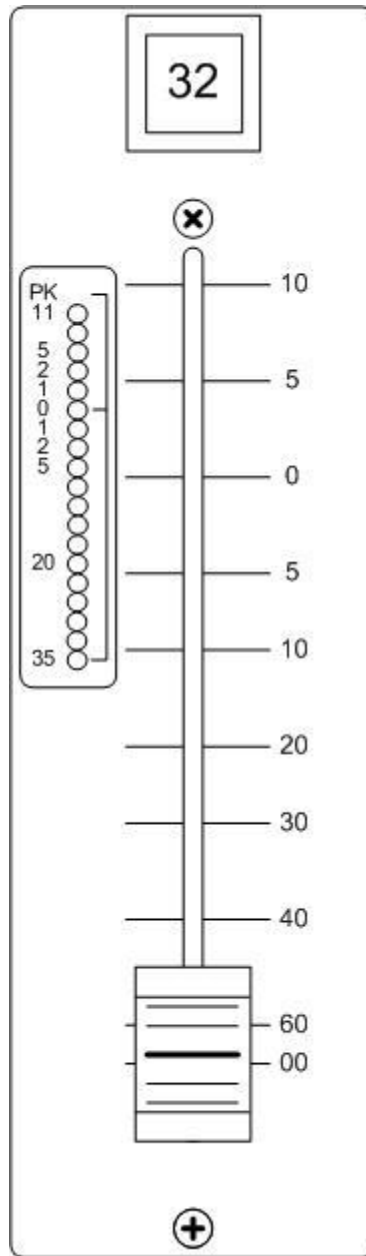

2.2 Mix Bus Masters

The 32Classic features 2 different types of mix bus module. The modules for mix buses 1-2, 3-4, and 5-6 each have one of the 3 the Cue/Matrix masters in addition to the mix bus fader and controls. The module for mix buses 7-8 instead has the master controls for the Aux buses and the Return mix, as well as the console talkback section. It is covered in Section [2.2.2](#)

2.2.1 Mix Bus Masters 1-2, 3-4, 5-6 with Cue/Matrix Master

[Figure 8](#) shows the mix bus strip with cue/matrix output section.

Figure 8: MIX BUS MASTERS 1-2, 3-4, 5-6 WITH CUE/MATRIX

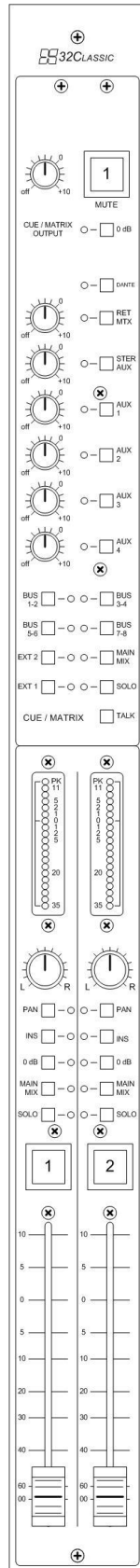

2.2.1.1 Mix Bus Master Section

The mix bus master section of the mix bus strip is shown in [Figure 9](#). There are identical sets of controls for 2 buses. These are outlined in the following sections.

2.2.1.1.1 Mix Bus Fader and 0 dB Lock Button

A high quality 100mm fader controls the final output level of the mix bus.

If engaged, the 0 dB lock button will disable the fader so that the bus output level is always at the 0 dB nominal level regardless of the fader position.

2.2.1.1.2 Mute Button

The large illuminated Mute button mutes the mix bus output.

2.2.1.1.3 Solo Button

The solo button solos the post-fader mix bus signal. The mix bus signal is taken post pan knob to the stereo solo bus. If the bus PAN button is not engaged the post-fader mix bus signal will be applied equally to the left and right sides of the solo bus.

2.2.1.1.4 INS Button

The Insert button enables the insert point ahead of the mix bus fader. Like on the channel strips, insert send and return connections are on DB25 connectors (see [Section 3.3](#)). Again, unlike other consoles where the insert connections are on jacks, engaging the INS button with no external equipment connected will result in no signal. The LED indicator associated with this switch will show when the insert is engaged.

2.2.1.1.5 Main Mix Assign Button and Pan Control

The red Main Mix button routes the mix bus post-fader output to the main stereo mix. If the Pan switch is engaged, the Pan knob adjusts panning to the main mix left and right buses.

Figure 9: MIX BUS MASTER SECTION ON BUS 1-2, 3-4, 5-6

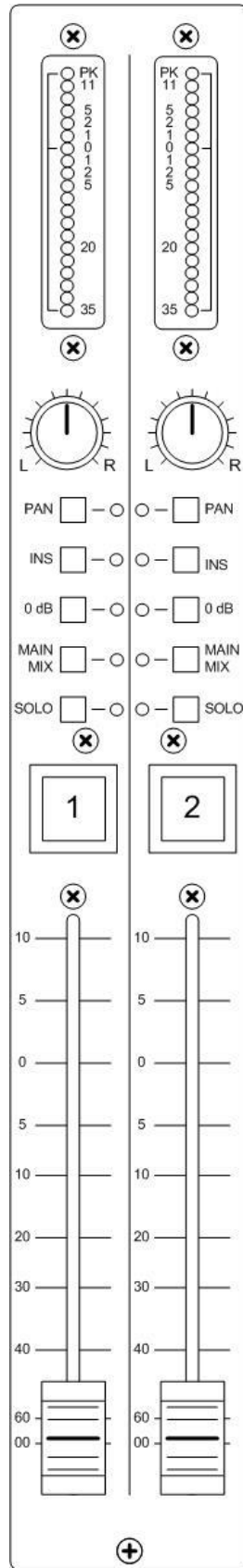

2.2.1.1.6 LED Level Meter

The 20 segment LED meter indicates the mix bus output level over the range –35 dBu to +14 dBu. An internal jumper determines whether the meter reads the pre or post-fader signal.

2.2.1.2 Cue/Matrix Output Section

Cue/Matrix section of the bus strip is used to create alternate mixes such as (but not limited to) cue or headphone mixes. The 3 available Cue/Matrix mixes (one from each of the first 3 mix bus strips) are completely independent. These mixes are stereo. A mix can be built from any combination of the 8 mix buses (as stereo pairs), the main stereo mix, the 5 Aux buses, the Return mix, a pair of inputs from dedicated channels on the Dante interface, and 2 additional analog stereo external inputs.

Figure 10 shows the Cue/Matrix section of the bus strip.

2.2.1.2.1 Cue/Matrix Level Control and Mute

The rotary knob controls the output level of the cue/matrix. The 0 dB lock button when engaged, disables the level knob and sets the output to the 0 dB nominal level.

The large illuminated Mute button mutes the cue/matrix output.

2.2.1.2.2 Dante Button

The Dante button routes 2 channels from the Dante interface into the cue/matrix mix. Each cue/matrix mix has a dedicated pair of channels from the Dante interface, one of which routes to the Left side of the Cue/Matrix output, the other to the Right side. No level control is provided.

2.2.1.2.3 Return Mix Button and Level

The Return Mix button routes the stereo output from the Return Mix master (which is on the bus 7-8 strip) into the cue/matrix mix. A mix level control is provided.

2.2.1.2.4 Aux Mix Buttons and Level controls

Each Aux bus output has a routing button and mix level control into the Cue/Matrix mix. The mono Auxes 1-4 are applied equally to both sides of the stereo Cue/Matrix mix. The stereo Aux routes stereo into the Cue/Matrix mix.

Figure 10: MIX BUS CUE/MATRIX SECTION

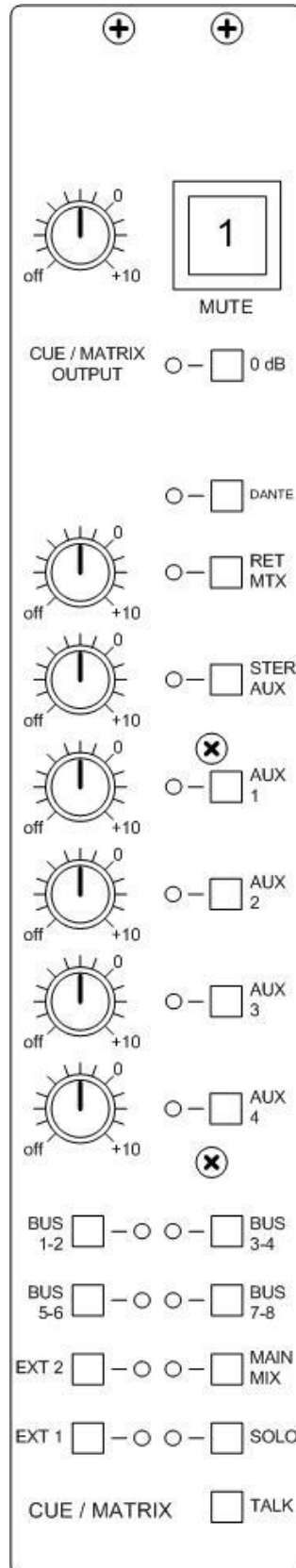

2.2.1.2.5 Mix Bus and Main Stereo Mix Assign Buttons

The 8 mix buses are assigned as L-R stereo pairs into the Cue/Matrix mix. The main stereo mix routes stereo into the Cue/Matrix mix. No individual level controls are provided.

2.2.1.2.6 EXT1 and EXT2 Assign Buttons

These buttons assign 2 external stereo pairs of analog inputs to the Cue/Matrix mix. No individual level controls are provided. The same 2 stereo pairs are available to all 3 Cue/Matrix mixes. These same EXT1 and EXT2 inputs can also be input to the Monitor section on the Master module.

2.2.1.2.7 Source Summing

The various sources into the Cue/Matrix mix given in Sections [2.2.1.2.2](#) through [2.2.1.2.6](#) are not mutually exclusive. If more than one of these sources is selected into the Cue/Matrix bus they will all sum to produce the final Cue/Matrix mix. Note that only the 5 Auxes and the Return Mix have individual level controls into this mix. Buses and main stereo mix do not have level controls into this mix, but their signals are sourced post fader. External and Dante inputs do not have individual level controls into this mix.

2.2.1.2.8 Solo Button

The solo button solos the post output level knob stereo cue/matrix signal to the stereo solo bus. If the 0dB button is engaged causing the output level knob to be disabled, the soloed signal will be at the 0dB nominal level.

2.2.1.2.9 Talk Button

The TALK button routes the console built-in talkback mic to the Cue/Matrix mix. The mic is applied to the mix Left and Right equally. Level control is at the talkback master section on the mix bus 7-8 strip. The button is non-latching so the talkback signal is routed to the Cue/Matrix mix only while the TALK button is pushed.

- TALK overrides all other input signals to the Cue/Matrix output

2.2.2 Mix Bus Master 7-8 With Aux Master/Return Master

[Figure 11](#) shows the Mix Bus 7-8 strip which also has the Aux Master, Return Master and Talkback sections.

Figure 11: MIX BUS MASTER 7-8 WITH AUX MASTER/RETURN MASTER

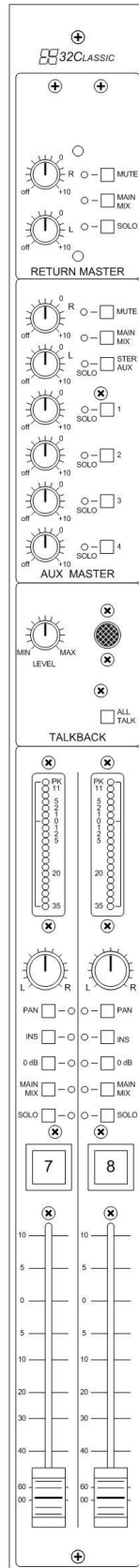

2.2.2.1 Mix Bus Master Section

The mix bus master section shown in [Figure 12](#) is identical to that on mix bus masters 1-2, 3-4 and 5-6, and has the same controls as outlined in the following sections.

2.2.2.1.1 Mix Bus Fader and 0 dB Lock Button

A high quality 100mm fader controls the final output level of the mix bus.

If engaged, the 0 dB lock button will disable the fader so that the bus output level is always at the 0 dB nominal level regardless of the fader position.

2.2.2.1.2 Mute Button

The large illuminated Mute button mutes the mix bus output.

2.2.2.1.3 Solo Button

The solo button solos the post-fader mix bus signal. The mix bus signal is taken post pan knob to the stereo solo bus. If the bus PAN button is not engaged the mix bus signal will be applied equally to the left and right sides of the solo bus.

2.2.2.1.4 INS Button

The Insert button enables the insert point ahead of the mix bus fader. Like on the channel strips, insert send and return connections are on DB25 connectors (see [Section 3.3](#)). Again, unlike other consoles where the insert connections are on jacks, engaging the INS button with no external equipment connected will result in no signal. The LED indicator associated with this switch will show when the insert is engaged.

2.2.2.1.5 Main Mix Assign Button and Pan Control

The red Main Mix button routes the mix bus post-fader output to the main stereo mix. If the Pan button is engaged, the Pan knob adjusts panning to the main mix left and right buses.

2.2.2.1.6 LED Level Meter

The 20 segment LED meter indicates the mix bus output level over the range -35 dBu to $+14$ dBu. An internal jumper determines whether the meter reads the pre or post-fader signal.

Figure 12: MIX BUS MASTER SECTION ON BUS 7-8

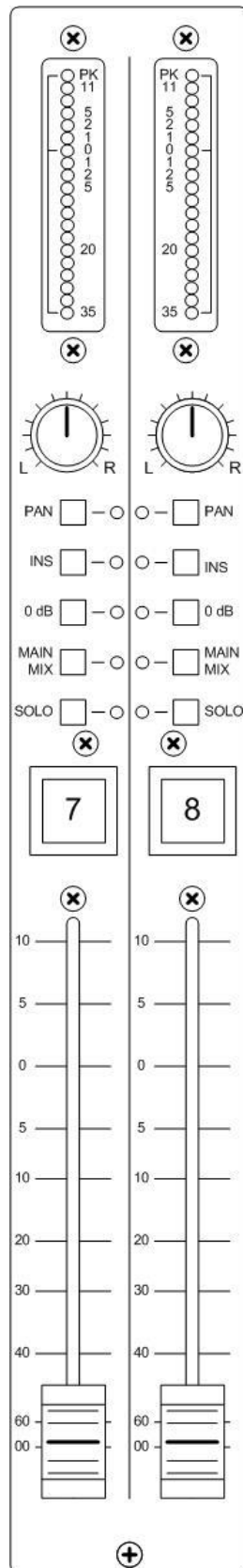

2.2.2.2 Return Master Section

The Return bus sums 32 analog inputs available on 4 D25 input connectors. The Left and Right assign buttons are at the top of each channel strip as shown in [Figure 3](#), but these input signals are not otherwise present on or associated with the channels. The master controls for the stereo Return bus are at the top of bus strip 7-8, as shown in [Figure 13](#).

Figure 13: RETURN BUS MASTER

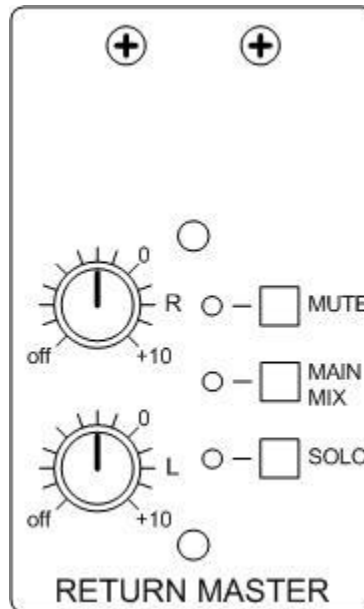

2.2.2.2.1 Return Bus Master Level Control and Mute

The rotary knobs control the output level of the Return bus. Separate knobs are provided for Left and Right outputs. The Mute button mutes both sides of the Return output.

2.2.2.2.2 Main Stereo Mix Assign Button

The red Main Mix button routes the Return bus post level controls output to the main stereo mix.

2.2.2.2.3 Solo Button

The solo button solos the post-level control Return bus signal outputs. The stereo Return bus output signal is taken post level controls 1:1 to the stereo solo bus. Also, the solo feeds are post MUTE button, if the MUTE button is engaged there will be no output to the solo bus.

2.2.2.2.4 Signal Indicator LEDs

Two large bi-color LED indicators are provided which display signal presence and clipping on each side of the Return mix. They read the signal at the mix sum points but ahead of the level controls.

2.2.2.3 Aux Master Section

This section contains the master controls for the 4 mono and 1 stereo Aux buses and is shown in Figure 14.

Figure 14: BUS STRIP 7-8 AUX MASTER SECTION

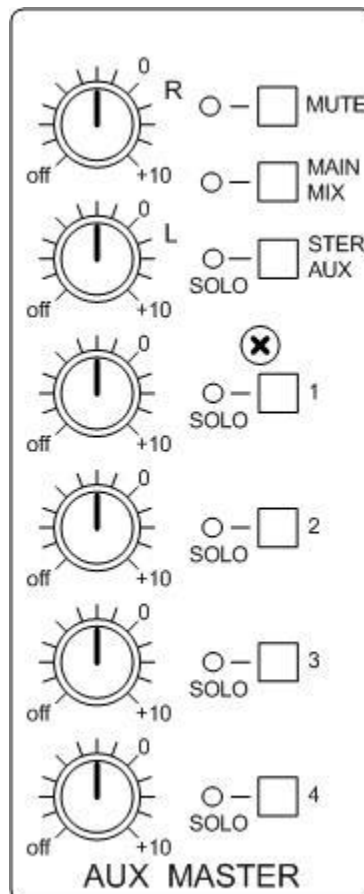

2.2.2.3.1 Aux Master Level Controls

Each Aux has a dedicated rotary control for master level. The Stereo Aux has separate Left and Right master level controls.

2.2.2.3.2 Aux Master Solo Buttons

Each Aux has a dedicated solo button reading post-level control. The mono auxes 1-4 solo equally to the left and right sides of the stereo solo bus. The stereo aux 5 solos 1:1 to the stereo solo bus.

2.2.2.3.3 Main Stereo Mix Assign Button

The red Main Mix button routes the Stereo AUX post level controls to the main stereo mix.

2.2.2.3.4 Stereo Aux Mute Button

The mute button mutes the stereo aux output and its send to the main stereo mix.

2.2.2.4 Talkback Section

This section controls the console Talkback features. The built-in electret microphone can be routed simultaneously to all 3 Cue/Matrix outputs by pressing the ALL TALK button. The rotary level control sets the talkback volume to the Cue/Matrix outputs. This button is non-latching so the talkback signal is routed to the Cue/Matrix mixes only while the ALL TALK button is pushed.

- ALL TALK overrides all other input signals to each Cue/Matrix output

The Talkback section is shown in [Figure 15](#).

Figure 15: BUS STRIP 7-8 TALKBACK SECTION

2.3 Master Module

Figure 16 shows the Master/Monitor module. This module has the following sections:

- Meter Mode/Dante status section provides global mode control for the LED meters, and status indicators for the Dante interface
- the front panel mic/instrument input and associated controls
- Main Mix option controls
- comprehensive monitoring section with 11.1 or 7.1.4 surround monitoring capability
- Main Stereo mix master fader and LED meters

The following sections will detail the features of each part of the Master strip.

Figure 16: 32CLASSIC MASTER MODULE

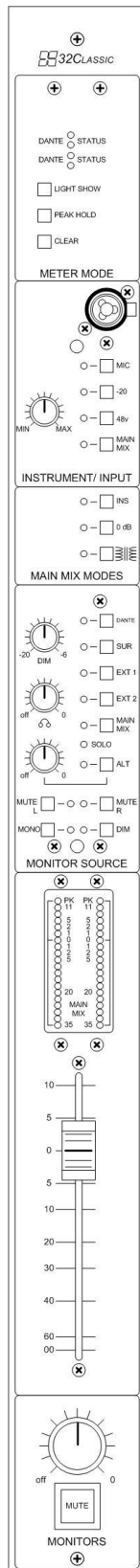

2.3.1 Meter Mode/Dante Status

This section is shown in [Figure 17](#).

Figure 17: METER MODE/DANTE STATUS SECTION



2.3.1.1 Dante Status

Four LEDs indicate status of the Dante ethernet interfaces. The console has 2 Dante interfaces attached to the ethernet network, one for channel strip I/O and one for the master section I/O. The top pair of LEDs indicate communication activity on the channel I/O, the lower pair LED indicates communication activity on the master section I/O. In each pair the upper LED is a power status indicator and the lower LED is a link activity indicator

2.3.1.2 LED Meter Controls

Three buttons globally control the operating mode of all LED meters on the console.

- PEAK HOLD is a latching button that selects peak hold mode on all meters. The LED indicating the peak level of the signal will be kept on until the peak is reset.
- CLEAR PEAK is a momentary button that clears the peak indicators on all meters
- LIGHT SHOW is a momentary button which resets all LED meters on the console. When reset the meters produce a dazzling light show to impress your customers, before entering normal operation

2.3.2 Mic/Instrument Input

This section features a Combo XLR jack that accepts either an XLR connector or a 1/4" guitar plug. This input may be selected as the input to any channel strip by selecting the INST button on the desired channel strip(s) (see Section [2.1.1.8](#)).

Figure 18: INSTRUMENT INPUT

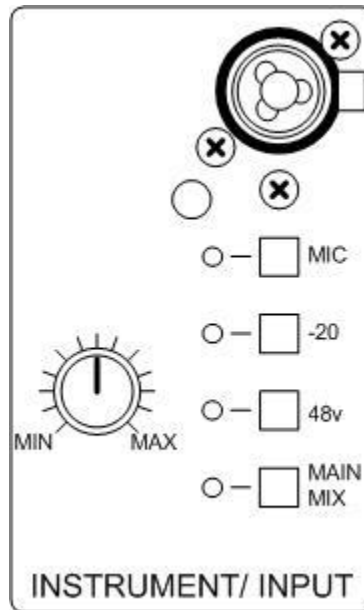

2.3.2.1 MIC Switch

This button selects whether the XLR or 1/4" input is to be used. When pressed, the input is set for a microphone input.

One important feature of this input is that the microphone preamp is identical to that on the channel strips. Having the same audio quality and tonal character as the channel strip ensures that last minute overdubs or additions using this input will sound exactly the same as those using the channel strip preamp.

2.3.2.2 -20 Switch

This button inserts a 20 dB pad at the microphone input ahead of the input gain stage.

2.3.2.3 48V Switch

This button provides 48V phantom power to the microphone input. This will be useful if condenser mics or active DI boxes are connected to the XLR input.

2.3.2.4 Gain Control

This rotary control sets the gain of the microphone/instrument input and functions as trim control to the channel strips selected to receive this input.

2.3.2.5 MAIN MIX Switch

This button assigns the mic/instrument input into the main stereo mix, via the level control. The signal is applied equally to Left and Right of the main mix.

2.3.3 Main Mix Modes Section

This section is shown in [Figure 19](#) and provides some options for the main stereo mix control shown in [Figure 20](#).

Figure 19: MAIN MIX MODES SECTION

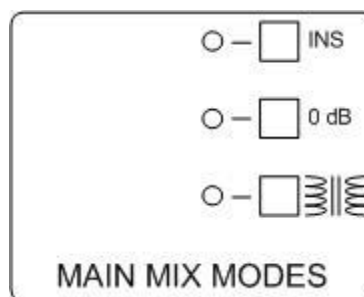

2.3.3.1 INS Button

The Insert button enables the insert points ahead of the main stereo mix fader. Like on the channel and bus strips, insert send and return connections are on DB25 connectors (see [Section 3.3](#)). Again, unlike other consoles where the insert connections are on jacks, engaging the INS button with no external equipment connected will result in no signal. The LED indicator associated with this switch will show when the insert is engaged.

2.3.3.2 Main Stereo Mix Fader and 0 dB Lock Button

Figure 20 shows the main Stereo mix fader section. The single high quality 100mm fader controls both the Left and Right mix outputs. The 20 segment LED meters indicate the Left and Right mix bus output levels over the range -35 dBu to +14 dBu. An internal jumper determines whether the meter reads the pre or post-fader signal.

If engaged, the 0 dB lock button in the "Main Mix Modes" section will disable the main mix fader so that the output level is always at the 0 dB nominal level regardless of the fader position.

Figure 20: MAIN MIX FADER SECTION

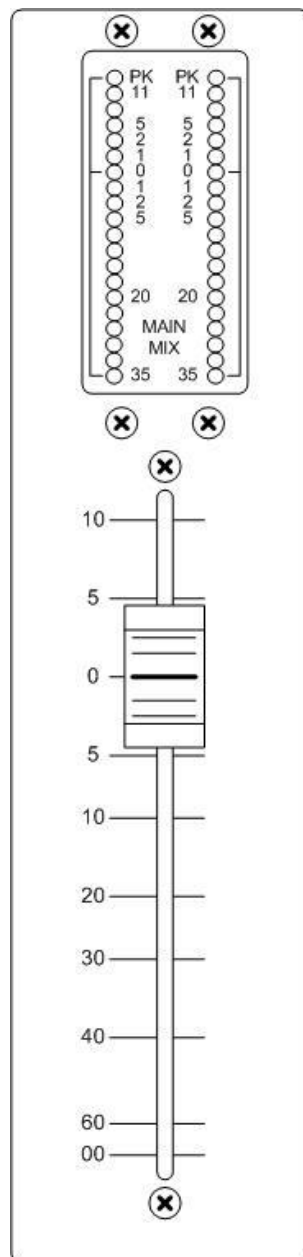

2.3.3.3 Main Mix Output Transformer Option

The main stereo mix outputs are electronically balanced, as are all other analog outputs on the console. If this button is engaged, a high quality Jensen output transformer will be introduced at the main mix output connector. The circuit design of this section features a proprietary technique used in some of our classic consoles of the past which optimizes the tonal coloration provided by the transformer.

2.3.4 Monitor Source Selection

The Monitor section provides comprehensive monitoring capabilities, including monitoring of 11.1 or 7.1.4 surround mixes from your DAW if needed.

Despite having relatively few controls, the capabilities of the console monitoring are substantial. The monitor section operation and signal flow will be presented in detail in Section [4.4.3](#).

The monitor source selection controls are shown in [Figure 21](#). The following sections outline the function of each.

Figure 21: MONITOR SOURCE CONTROLS

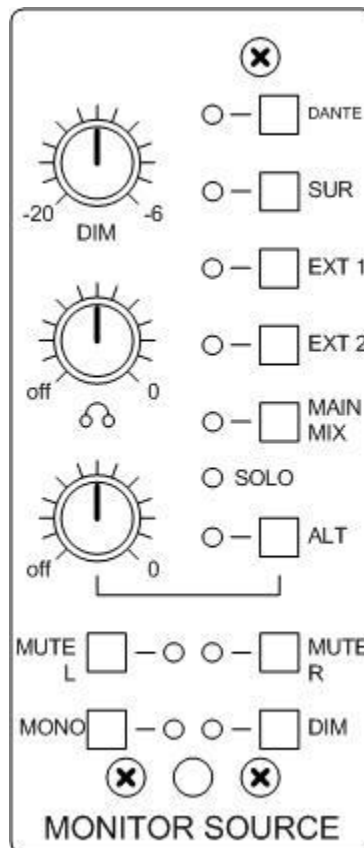

2.3.4.1 Dante Source

This button selects two channels on the Dante interface as the monitor source. This might be, for example, the monitor or main mix output of your DAW. This is not the same source as the Surround Dante Left Front/Right Front inputs.

2.3.4.2 EXT 1 and EXT2 Monitor Inputs

These buttons select the EXT1 and EXT2 external stereo analog inputs to be the monitor source. These are the same 2 stereo pairs which are available as inputs to the 3 Cue/Matrix mixes.

2.3.4.3 Main Mix Source

The Main Mix button selects the main stereo mix as the monitor source.

2.3.4.4 Surround Source

The SUR button selects a 12-channel wide surround source to be monitored from the Dante interface and routes these signals to the console's 12 surround monitor outputs. The console's Left and Right monitor outputs are replaced by the Left Front and Right Front monitor inputs from the *surround* Dante interface. Thus, this monitor selection only provides monitoring of the 12 channel external source from the Dante interface and nothing of what is going on in the console.

For details of the monitoring architecture and surround monitoring capability, refer to Section [4.4.3](#).

2.3.4.5 Monitor Source Summing

The monitor source selection is not exclusive. If more than one of Main Mix, External inputs or Dante input are selected as monitor sources, they will be summed to the main L-R monitor outputs without individual level control. Note that the selected monitor source(s) are replaced completely by the Surround Dante inputs when the SUR button is selected.

2.3.4.6 SOLO LED

This LED indicates that the monitor section is soloing something on the console. It is not rude as on some other consoles.

2.3.4.7 Alternate Monitor Output and Level Control

The ALT button switches the monitor output from the main monitor speaker output to the alternate speaker output. The typical use for the Alternate output might be for a pair of small nearfield speakers placed on the console meter bridge. The alternate output has its own volume control, which facilitates matching levels compared to the main monitor speakers.

2.3.4.8 DIM Button and Control

When pressed the DIM button dims the monitor outputs by the amount adjusted by the DIM control. The range of dimming is between -20 dB and -6 dB.

2.3.4.9 Headphone Volume Control

This knob controls the level of the headphone output. The headphone feed is taken ahead of the main monitor level control and muting and so is not affected by them.

2.3.4.10 MONO Button

When this button is engaged, left and right sides in the monitoring path will be summed to produce a mono output signal. This is intended to check for mono compatibility of the mix. Note that only the monitoring over the speaker outputs is summed to mono, the main stereo mix and its outputs from the console are NOT affected.

2.3.4.11 Left and Right MUTE buttons

The Left and Right sides of the monitoring path may be independently muted using these buttons. Only the Main and Alternate Speaker outputs are muted, the headphone output is not affected.

2.3.5 Monitor Level Control

The main level control and main mute button for all monitor/speaker outputs are shown in [Figure 22](#). The large illuminated MUTE button affects all 12 surround monitor outputs (which includes the main left and right monitor outputs) as well as the Alternate monitor output.

The large level control knob affects the 12 surround outputs but not the Alternate monitor output, which has its own level control as described earlier.

Note that the level and mute controls are placed at the bottom of the master strip below the main stereo mix fader. This is in anticipation that the control room monitor level will be adjusted

more frequently than the main stereo mix level, and should prevent inadvertently bumping the main fader when adjusting the monitoring level.

Figure 22: MONITOR LEVEL CONTROL

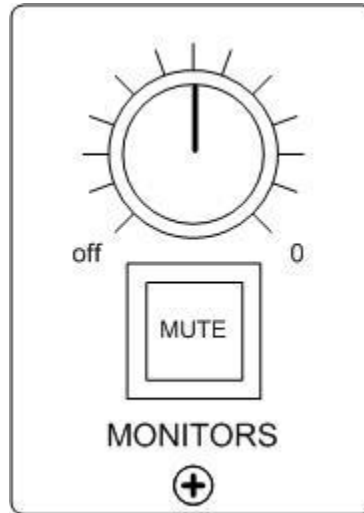

3.0 Console I/O Connections

3.1 I/O Connections Philosophy

Despite being a console optimized for use with a DAW, the 32Classic is still an analog console at its core. Accordingly, all of the console's basic inputs and outputs are analog.

For maximum flexibility and highest performance, all console inputs and outputs are active balanced on female DB25 connectors having standard Tascam/AES59 pinout (the main stereo mix can also be switched to a balanced transformer coupled output – see Section [2.3.3](#)). The Tascam/AES59 standard connector pinout is shown in [Figure 23](#). Straight through and breakout cables to other connector types are standard items readily available from pro audio dealers.

These connectors are situated on the console motherboards and are accessed from the underside of the console. By hanging straight down, all console I/O cabling can be dressed to eliminate the usual rat's-nest of cabling behind a typical analog console. If the control room has a raised false-floor, cabling can even be hidden in the console legs and pass through into the floor, providing a perfect clean installation.

Figure 23: TASCAM/AES59 STANDARD ANALOG DB25 CONNECTOR PINOUT

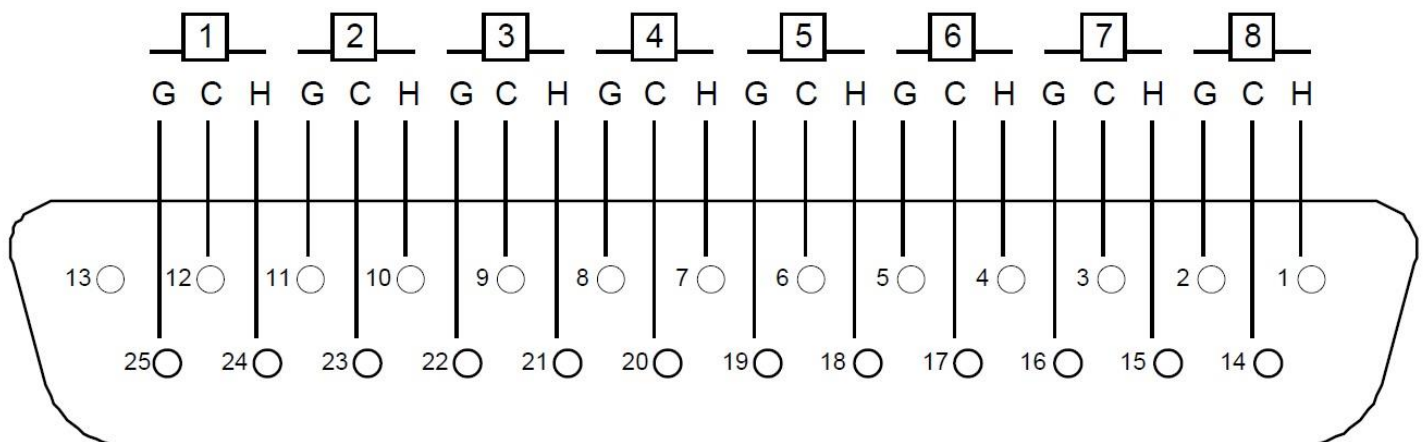

H = HOT
C = COLD
G = GROUND

[Figure 23](#) provides generic information. Each connector on the console and the specific signals available on it will be given in Sections [3.2.2](#) and [3.3.2](#).

3.2 Input Channel Strip Connections

All external audio connections to the channel strips are fully balanced on female 25-pin D-Sub connectors (DB25) arranged in groups of 8 channels. All connectors follow the standard Tascam/AES59 DB25 analog pinout shown in [Figure 23](#). The channel strips plug into motherboards carrying 8 channels each, and there are 8 D-sub connectors on each motherboard for the group of 8 channels. These are:

- mic inputs
- line inputs
- insert sends
- insert returns
- direct outs (analog)
- direct outs duplicated, nominally to Dante A/D
- playback inputs (nominally from Dante D/A)
- external Return Mix (called Line in B on the motherboards) inputs

[Figure 24](#) shows the I/O connectors for each group of 8 channels, as viewed from the underside of the console, as if you were lying on your back with feet towards the front of the console. The "narrow" side of the connectors are to your right from that perspective. Normally the DANTE OUT and PLAYBACK INPUT connectors will be pre-connected with a ribbon cable to the channels Dante card. The other connectors depend on your studio installation and will be uncommitted.

Each DB25 connector carries a particular signal for ALL channels on the motherboard. This is shown in [Figure 25](#).

Figure 24: CHANNEL STRIP CONNECTORS VIEWED FROM UNDERSIDE OF CONSOLE

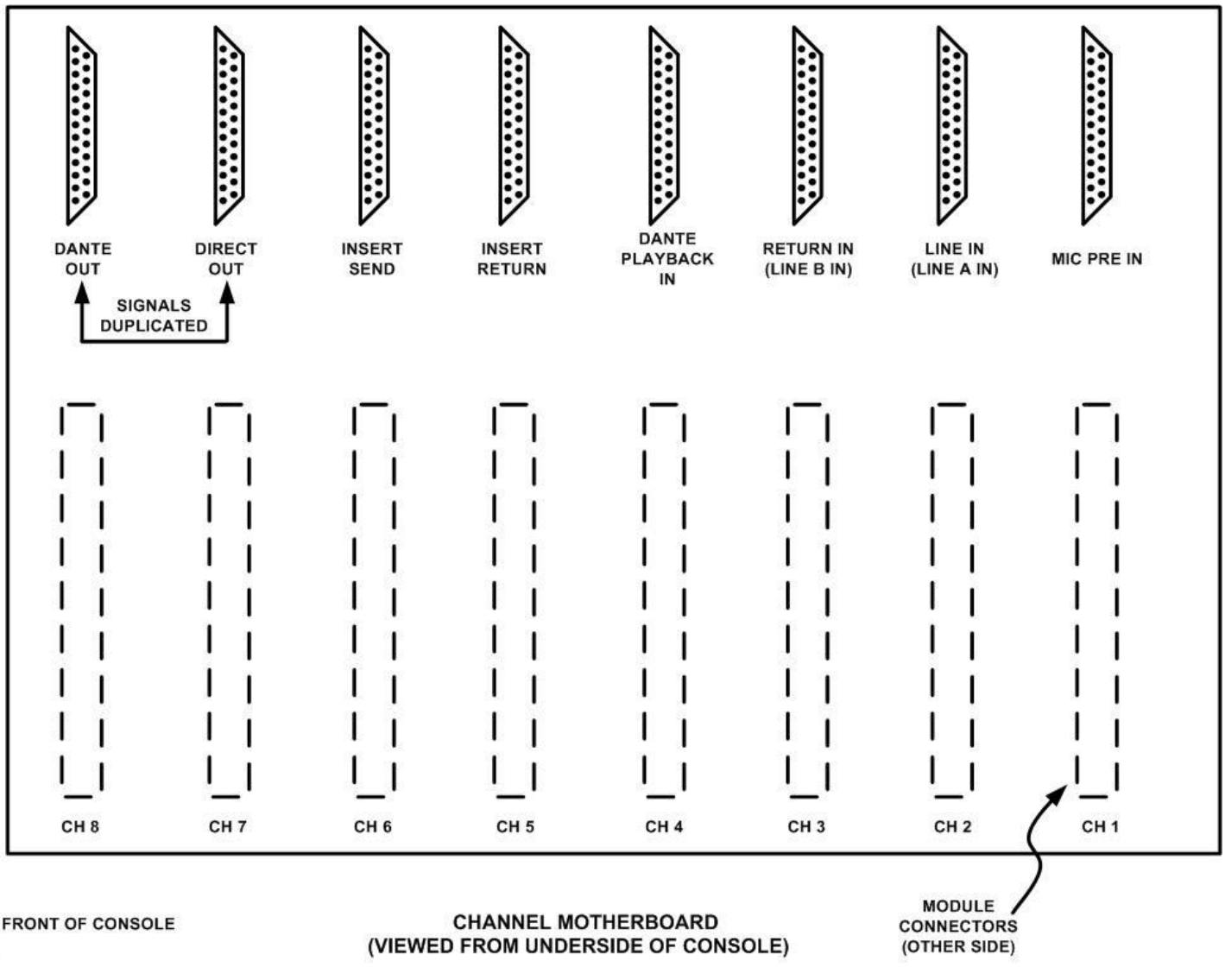

3.2.1 Channel Strip DB25 Connectors

Figure 25 shows the Input/Output connectors for each group of 8 channel strips. Four connectors supply the channel strip input signals, 2 are for insert in/out, and 2 are for direct outputs. The direct outputs are duplicated on 2 connectors, one nominally wired to the Dante interface to send the direct outputs to the user's DAW.

Figure 25: CHANNEL STRIP I/O CONNECTORS

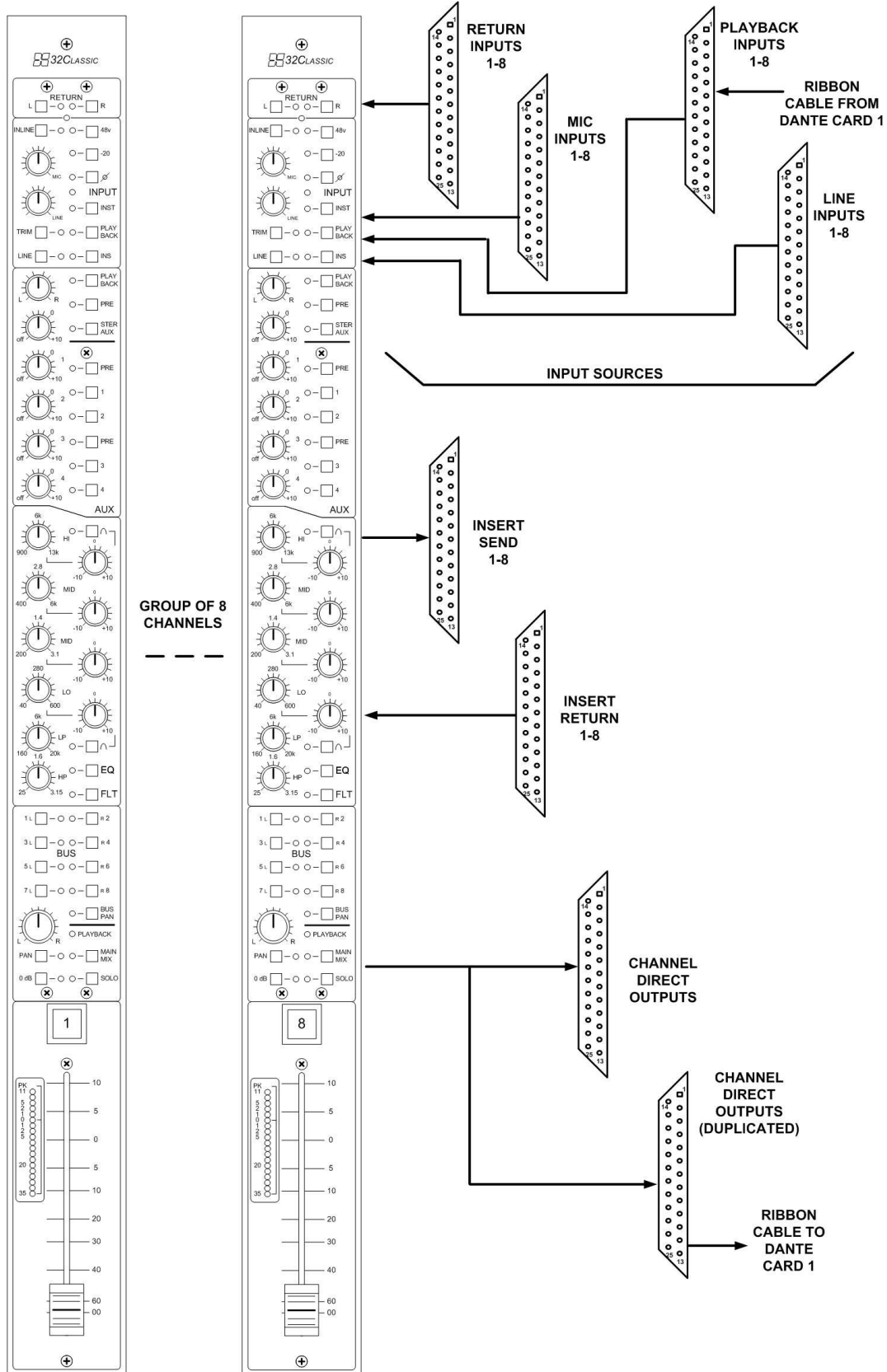

3.2.2 Channel Strip DB25 Connector Pinouts

Figure 26 shows the pinouts of each DB25 connector on the channel motherboard. The Line In and Return In connectors have identical pinout. The Direct Out and Dante Out connectors also have identical pinout as they duplicate the identical output signals.

Figure 26: CHANNEL MOTHERBOARD CONNECTOR PINOUTS

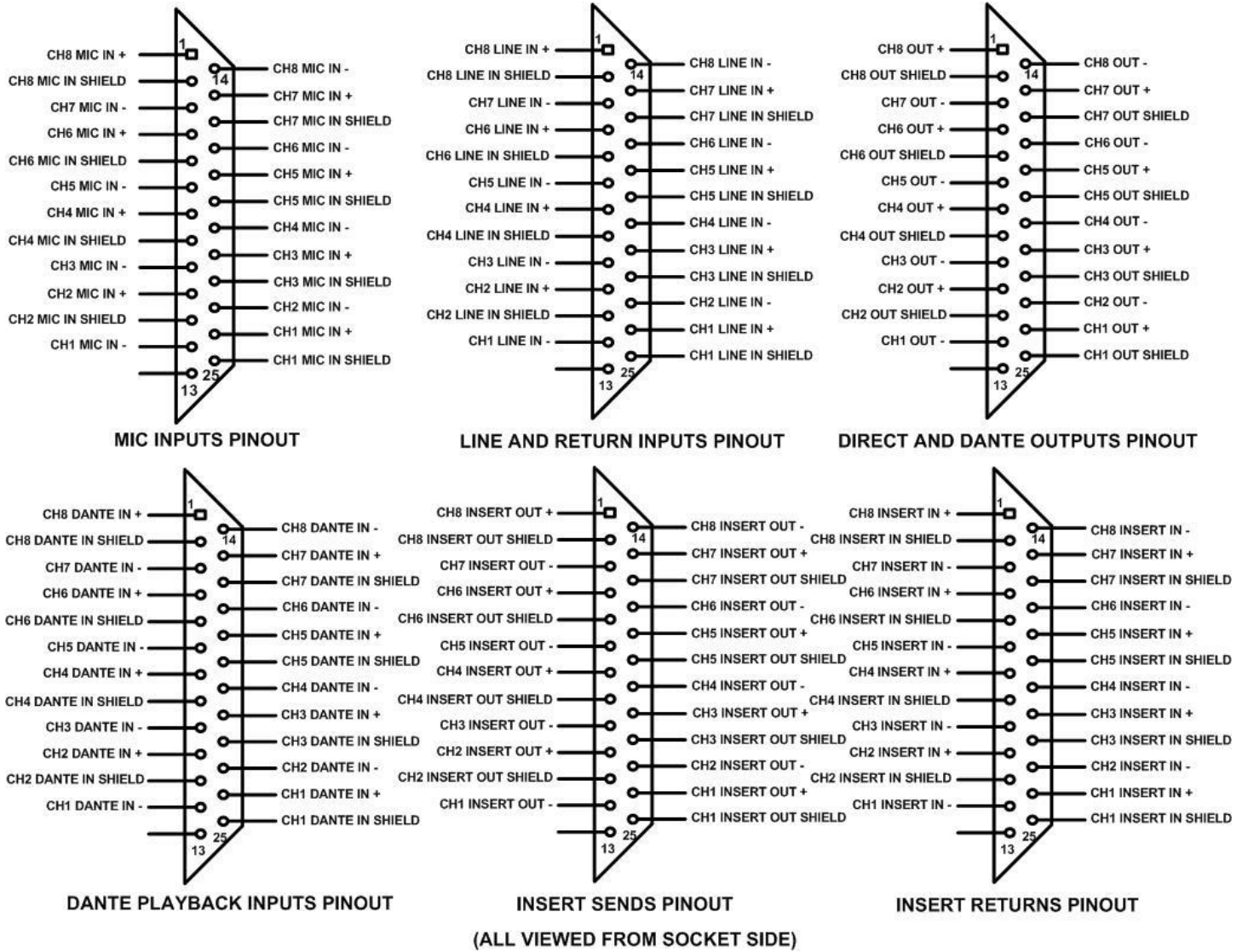

3.3 Group/Master/Monitor Section Connections

All external audio connections to the master section are fully balanced on female 25-pin D-Sub connectors (DB25). All connectors except one follow the standard Tascam/AES59 DB25 analog pinout shown in [Figure 23](#).

The 32Classic has a single motherboard for all of the Master/Monitor strips. This motherboard has 13 DB25 connectors for all of the master section ins and outs. These are:

- group outputs
- group outputs duplicated, nominally to Dante A/D
- group insert sends
- group insert returns
- main stereo mix and cue/matrix outputs
- main stereo mix and cue/matrix outputs duplicated, nominally to Dante A/D
- Dante inputs, 4 stereo pairs from Dante D/A to monitor section and 3 cue/matrix
- Aux and Return Mix outputs
- monitor speaker B outputs, stereo mix insert sends, Return Mix outputs duplicated
- stereo mix insert returns, 2 pairs of external analog inputs to monitor section
- 11.1/7.1.4 outputs 1-8 to monitor speakers
- external 11.1/7.1.4 surround inputs 1-8 from Dante D/A
- 11.1/7.1.4 outputs 9-12 to monitor speakers and inputs 9-12 from Dante D/A

[Figure 27](#) shows the I/O connectors for the master section, as viewed from the underside of the console, as if you were lying on your back with feet towards the front of the console. The "narrow" side of the connectors are to your right from that perspective. Normally the following connectors will be pre-connected with a ribbon cable to the master section Dante card:

- one group bus output
- one main stereo mix/matrix-cue output
- monitor/matrix-cue Dante in
- external 11.1/7.1.4 surround monitor in

The other connectors depend on your studio installation and will be uncommitted.

Figure 27: MASTER SECTION CONNECTORS VIEWED FROM UNDERSIDE OF CONSOLE

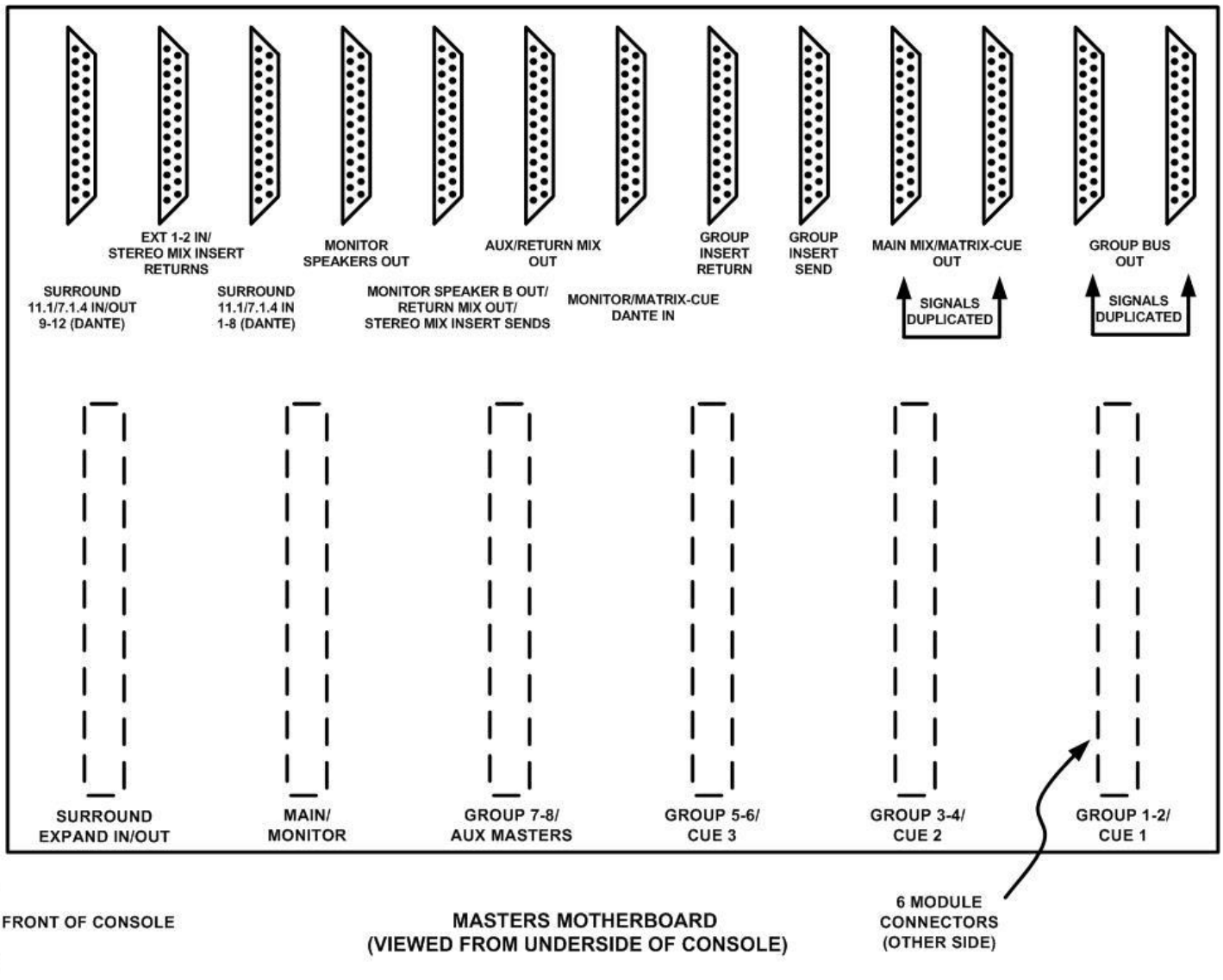

3.3.1 Master Section DB25 Connectors

Figure 28 shows the Input/Output connectors for the master section. Five connectors (2 duplicated) carry output signals for 8 subgroups, five Aux sends (one stereo), main stereo mix and 2 Cue/Matrix mixes. Another 2 connectors are for group insert in/out. The remaining 5 connectors are for 12 monitor speaker outputs, alternate main speaker output, main stereo mix insert in/out, Dante inputs to the Cue/Matrix buses, 12 surround inputs from the Dante card, and stereo external inputs to the monitor section.

Figure 28: MASTER SECTION I/O CONNECTORS

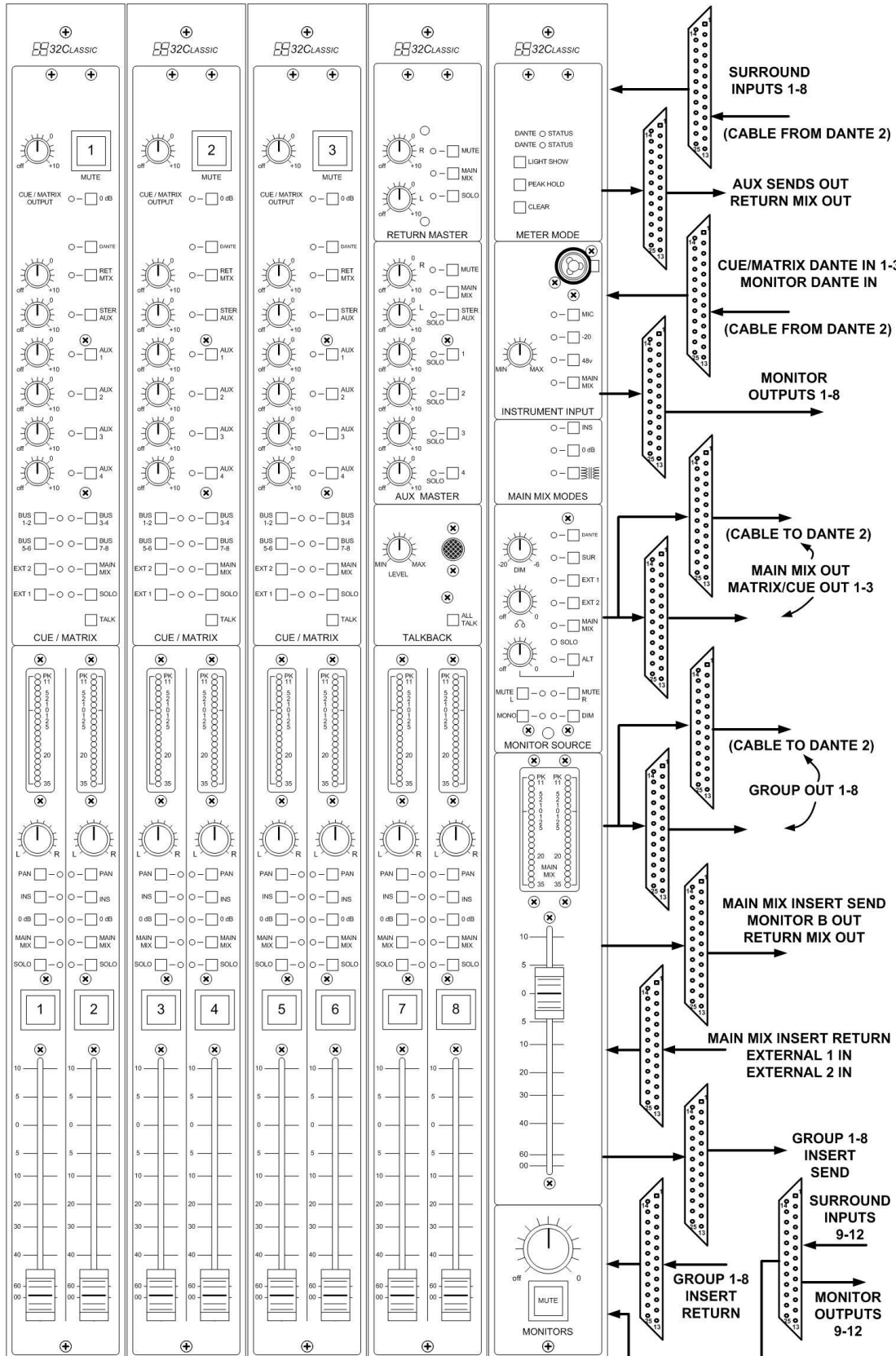

3.3.2 Master Section DB25 Connector Pinouts

Figure 29 shows the DB25 connector pinouts for 6 of the master motherboard connectors:

- group outputs (2 connectors duplicated)
- group insert sends
- group insert returns
- main stereo mix and cue/matrix outputs (2 connectors duplicated)

Figure 30 shows the DB25 connector pinouts for the following 4 master motherboard connectors:

- Monitor/Cue-Matrix Dante inputs (4 stereo pairs)
- Aux/Return Mix outputs
- monitor speaker B outputs, main stereo mix insert sends, Return Mix outputs duplicated
- surround outputs 1-8 to monitor speakers

Figure 31 shows the DB25 connector pinouts for the final 3 master motherboard connectors:

- surround monitor inputs 1-8 from Dante
- 2 stereo external analog inputs to monitor section, main stereo mix insert returns
- surround monitor Dante inputs 9-12 and surround outputs 9-12 to monitor speakers

3.3.2.1 Surround 9-12 Inputs and Outputs

Surround inputs 9-12 and their associated speaker outputs are an optional addition to the 32Classic to provide monitoring of 11.1 or 7.1.4 surround configurations. Note that unlike all the other I/O connectors, the connector has both inputs and outputs. The installation may be facilitated using off the shelf cables by noting that the pinout of this connector matches the wiring of Tascam/AES59 format AES-3/EBU breakout cables, which can also be used with analog signals. Alternately in the case of XLR breakout cables, the installer need simply replace 4 of the XLR connectors on a regular analog Tascam/AES59 cable with those of the opposite gender, or use gender reversing adapters.

Normally, the console will be supplied with the necessary cabling already installed to connect the Surround 9-12 inputs to the Dante source. The 4 analog speaker outputs will be provided on an additional local DB25 connector. See Figure 32.

Figure 29: MASTER MOTHERBOARD CONNECTOR PINOUTS - 1

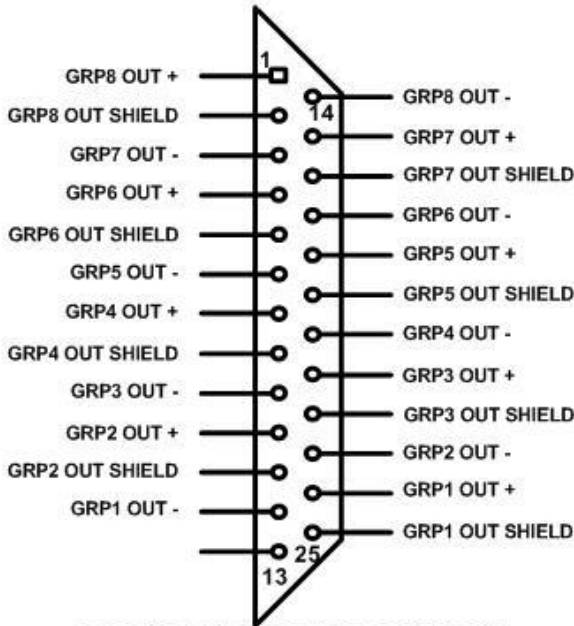

**GROUP BUS OUTPUTS PINOUT
(2 CONNECTORS)**

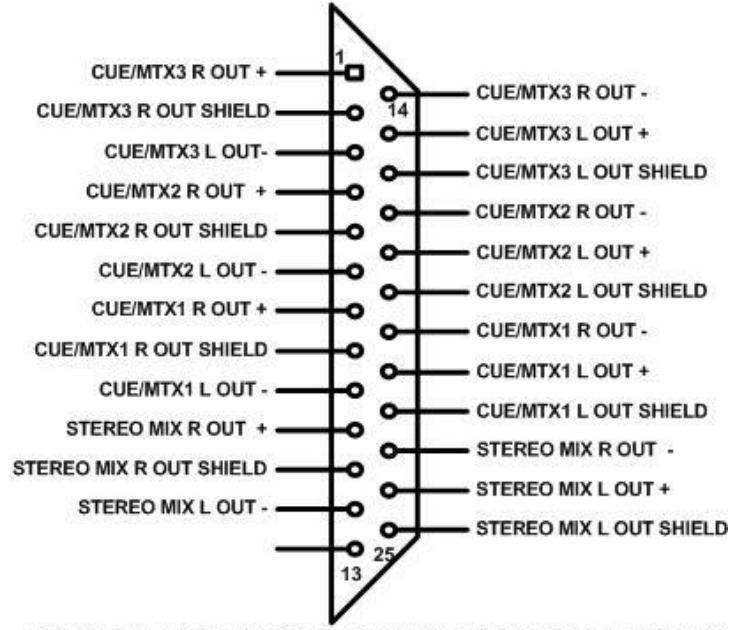

**MAIN STEREO MIX/MATRIX-CUE OUTPUTS PINOUT
(2 CONNECTORS)**

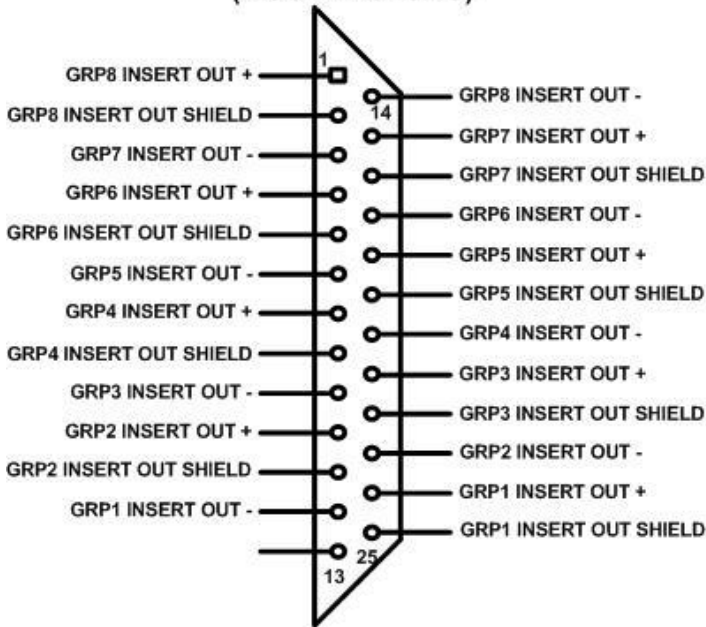

GROUP INSERT SENDS PINOUT

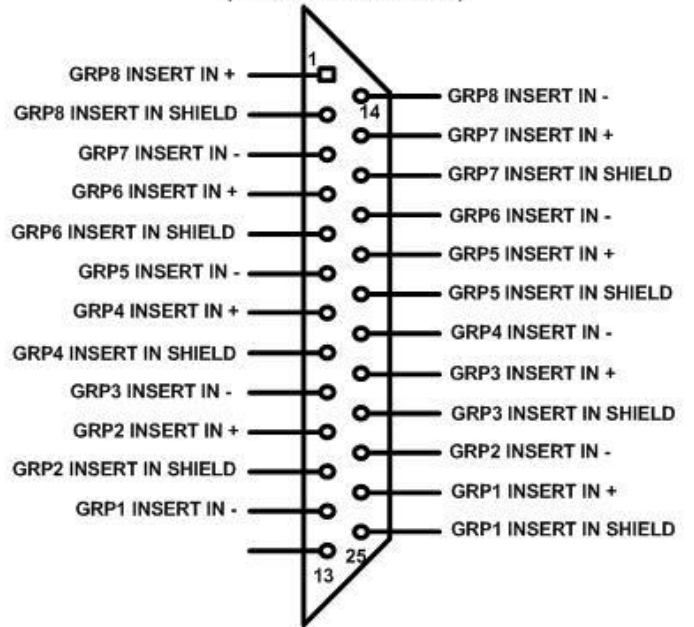

GROUP INSERT RETURNS PINOUT

(ALL VIEWED FROM SOCKET SIDE)

Figure 30: MASTER MOTHERBOARD CONNECTOR PINOUTS – 2

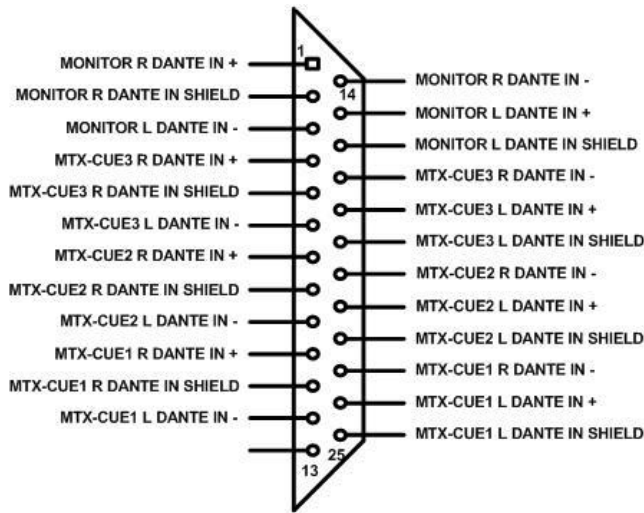

MONITOR/MATRIX-CUE DANTE INPUTS PINOUT

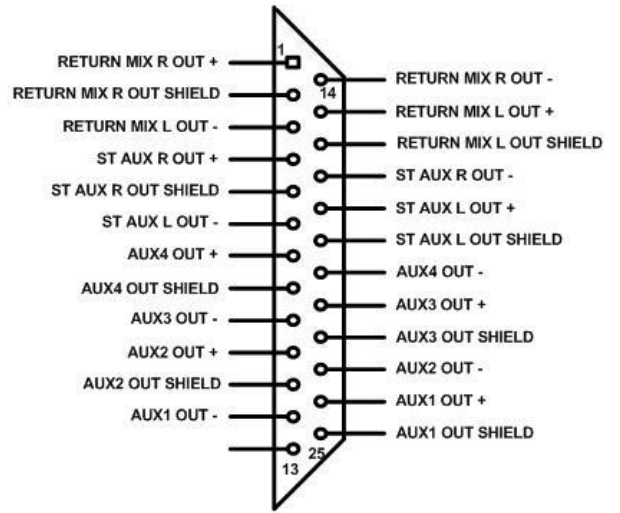

AUX/RETURN MIX OUTPUTS PINOUT

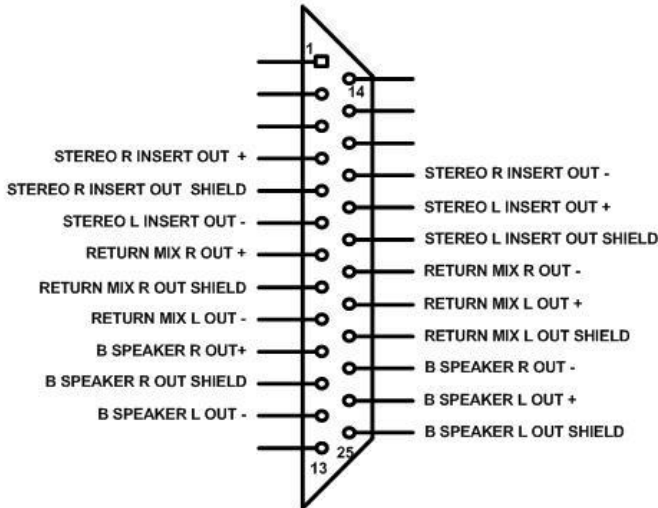

B SPEAKER/RETURN MIX/STEREO INSERT SEND OUTPUTS PINOUT

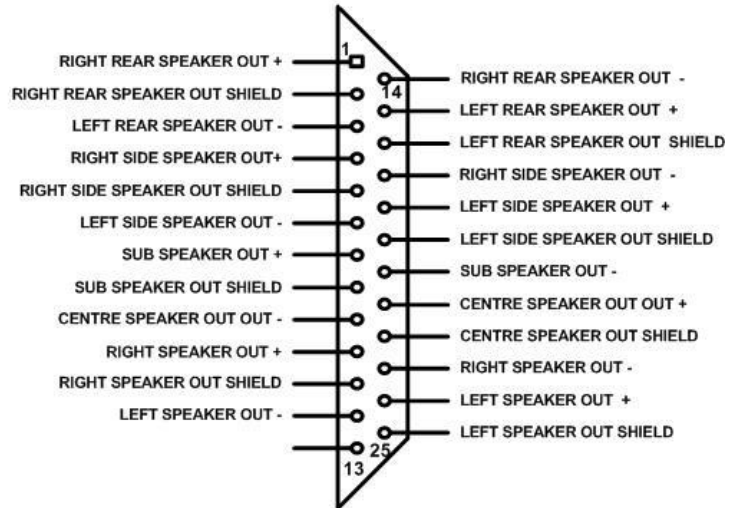

MONITOR SPEAKERS OUTPUTS PINOUT

(ALL VIEWED FROM SOCKET SIDE)

Figure 31: MASTER MOTHERBOARD CONNECTOR PINOUTS – 3

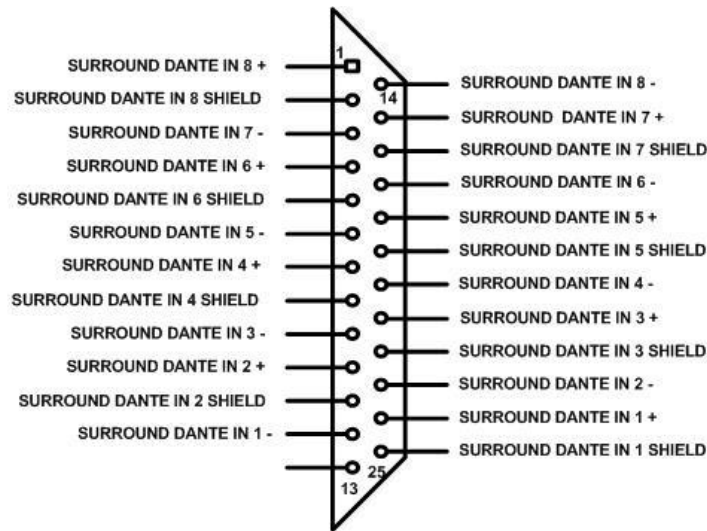

SURROUND MONITOR DANTE INPUTS 1-8 PINOUT

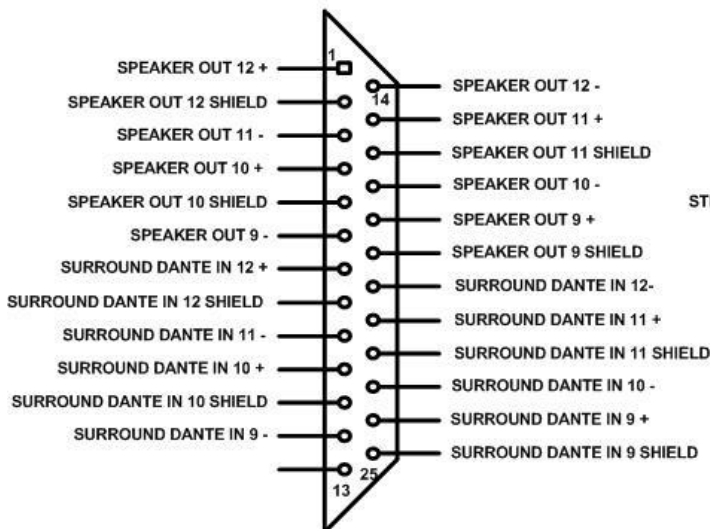

SURROUND MONITOR DANTE INPUTS 9-16 AND SPEAKER OUTPUTS 9-16 PINOUT

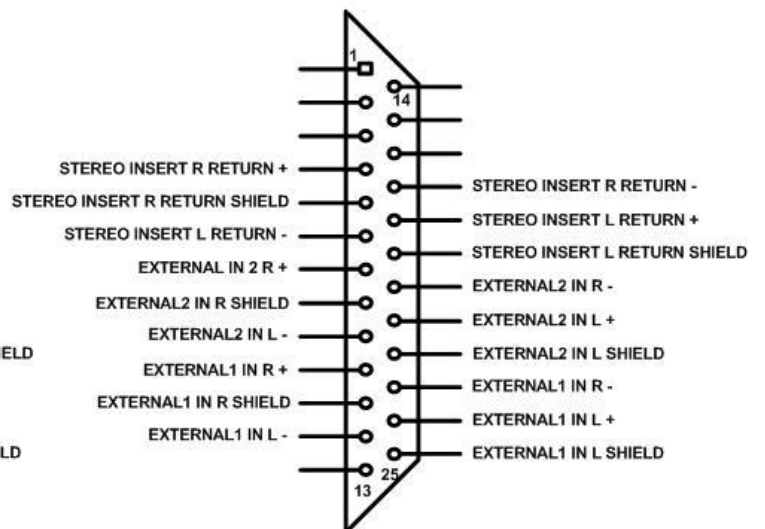

EXTERNAL ANALOGUE INPUTS/STEREO INSERT RETURN PINOUT

(ALL VIEWED FROM SOCKET SIDE)

3.4 Dante Interface Connections

3.4.1 Overview

One of the advanced and unique features of the 32Classic is its integrated A/D and D/A converters and Dante interface, whose provision provides a direct Ethernet interface to a computer running your favourite DAW.

Dante interfaces can carry up to 64 channels at 44.1/48 KHz sampling rate and 32 channels at 88.2/96 KHz sampling rate. Because the 32Classic is laid out as a 32 channel console and it is expected most music recording will be done at 96 KHz, only 32 channels on the interfaces are configured. Keeping 96 KHz operation in mind there are 2 physical Dante interfaces present internally, one for the channel I/O and one for the Buses/Master/Monitor section I/O. These are combined by an integrated Ethernet switch to result in a single Ethernet interface to the DAW computer. The console will appear as 2 devices on the Dante network.

The console will normally be supplied with the connections to the converter cards and Dante interface already installed. The console inputs and outputs assigned to the Dante interface are as follows:

- Direct outputs from each channel (total 32)
- Playback inputs to each channel (total 32)
- 11.1/7.1.4 Surround playback inputs to the Monitor section (total 12)
- 4 stereo inputs to 3 Cue/Matrix masters and the main Left-Right stereo mix (total 8)
- Group bus outputs (total 8)
- Main stereo mix and 3 stereo Cue/Matrix mix outputs (total 8)

The following console outputs have duplicated connectors so that they are available as both analog outputs and also on the Dante interface:

- channel direct outputs
- Group bus outputs
- Main stereo mix and 3 stereo Cue/Matrix mix outputs

Note that the Dante interface for the Master section is not completely filled, at only 20 channels in and 16 channels out. Future expansion is possible, and the unused Dante channels are available for any desired other purpose by direct connection into the converter/Dante cards. This will be explained in the next section.

3.4.2 Analog Connections to Converters and Dante

A/D and D/A conversion and Dante interfaces are contained on two circuit cards each carrying 32 channels each direction. One card is for Dante I/O on the 32 console channels, the

other card is for Dante I/O on the buses/Master/Monitor section. Interconnection to the console analog I/O is made with standard DB25 ribbon or snake cables as shown in [Figure 32](#).

Figure 32: CONNECTIONS TO CONVERTER/DANTE CARDS

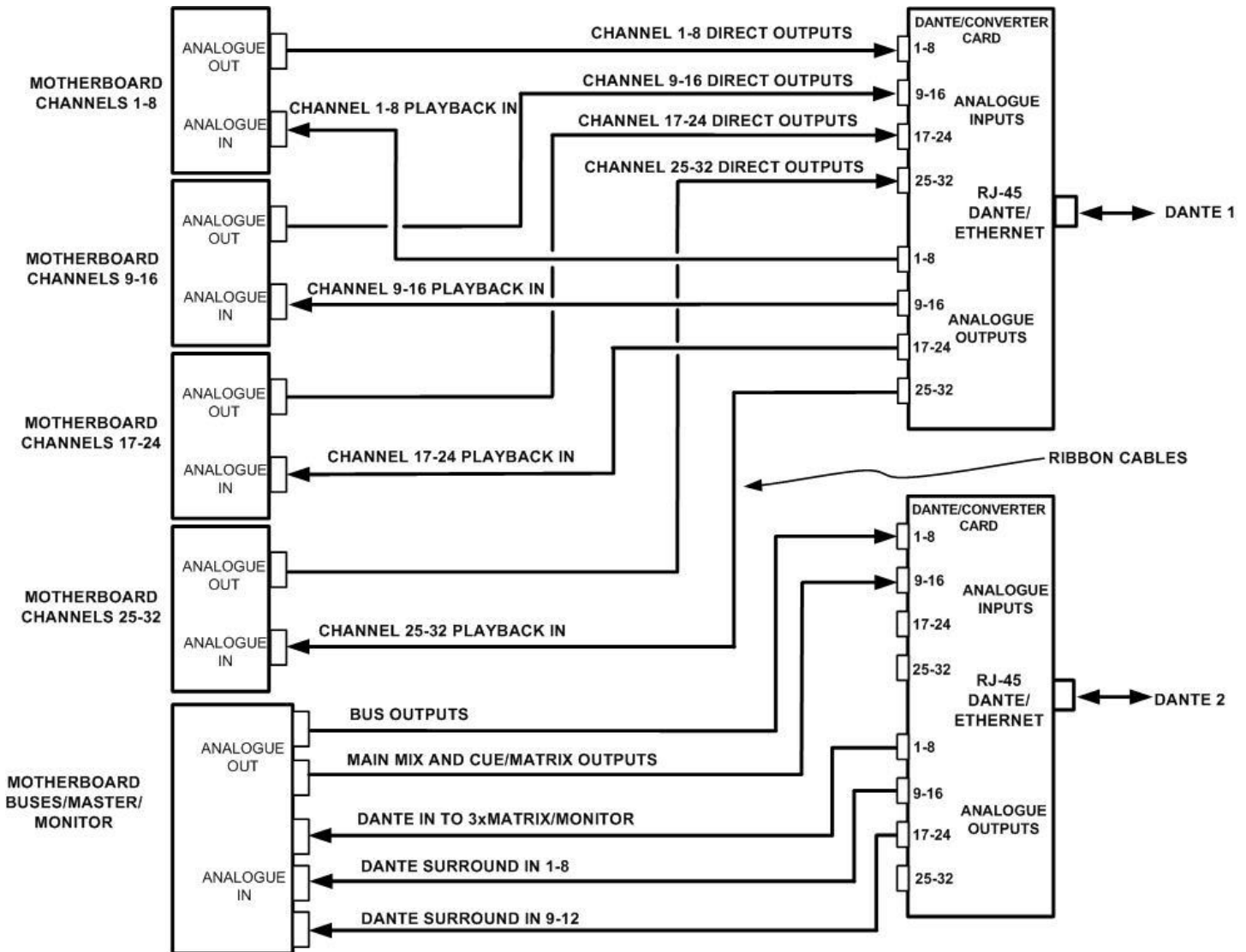

The channel Direct outputs and Playback inputs are connected to the first converter/Dante card. Main Stereo mix, Cue/Matrix and Mix bus outputs along with surround and 4 pairs of stereo inputs from the Dante are connected to the second converter/Dante card. As noted earlier not all Dante channels are used on the second converter/Dante card. As seen in [Figure 32](#) the connectors to the unused channels are uncommitted and access to use these channels only requires appropriate connection to them.

If the user or installer chooses not to use any part of the Dante interface into or out of the console, or to use the Dante for other purposes its inputs and outputs can be accessed by simply disconnecting the cables, likewise for the corresponding analog inputs and outputs on the

console. As noted in the last section, the analog outputs for channel direct outputs, group bus outputs, main stereo mix and Cue/Matrix mix outputs are on duplicated connectors. It is thus unnecessary to disconnect these outputs from the Dante card when analog connection to these outputs is desired. See Sections [3.2.1](#) and [3.3.1](#) for details.

3.4.3 Converter/Dante Interface Cards

Each converter/Dante card contains:

- 32 channels of professional grade A/D conversion
- 32 channels of professional grade D/A conversion
- Ethernet based Dante interface on RJ45 jacks
- TTL wordclock input

The block diagram of the converter/Dante cards is shown in [Figure 33](#).

Figure 33: CONVERTER/DANTE CARD BLOCK DIAGRAM

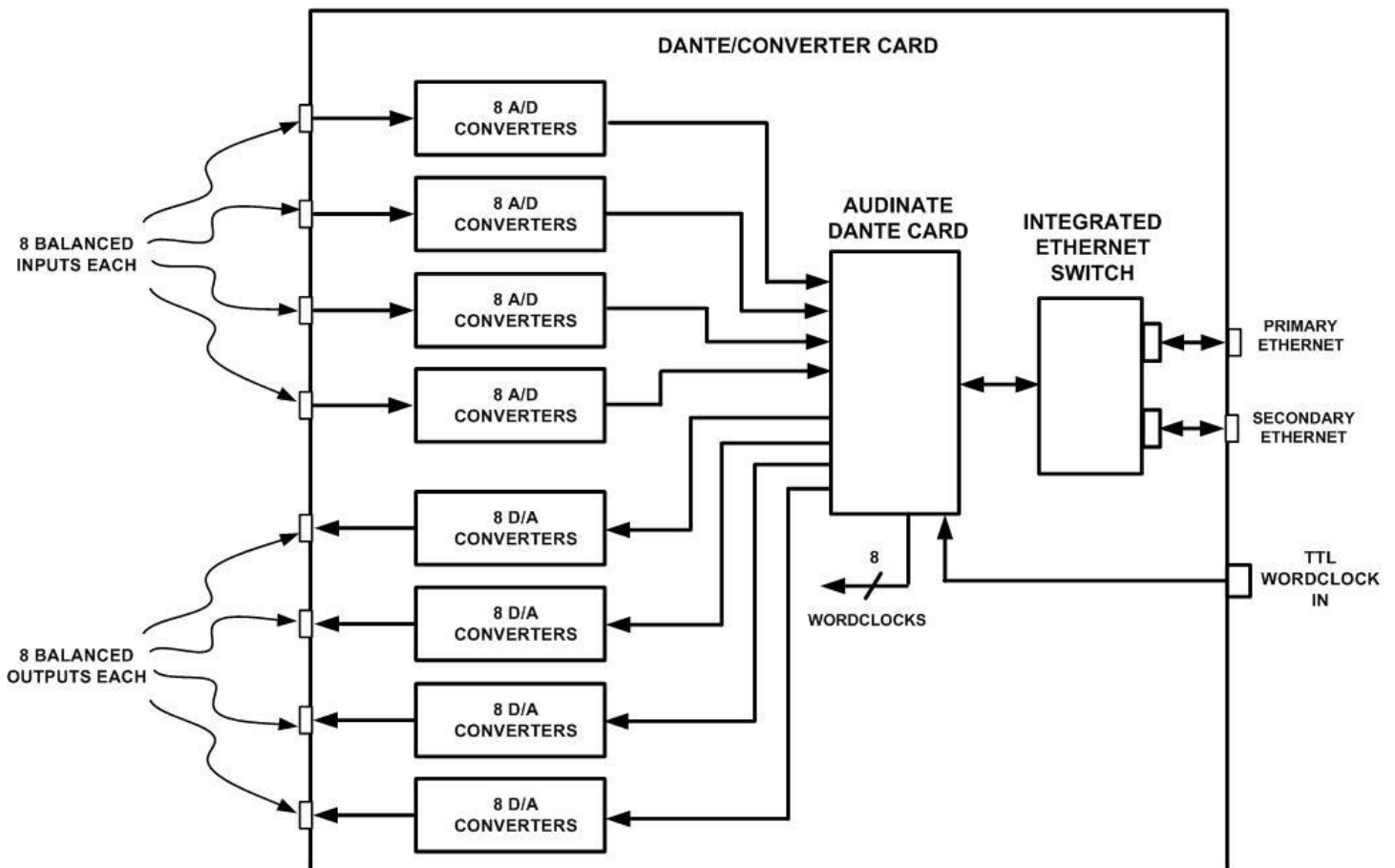

Analog input and outputs are nominal +4 dBu level on DB25 connectors. The converters are directly interfaced to an Dante interface module. Supporting the Dante module is a multiport Ethernet switch with integrated Gigabit Ethernet PHYs. Two Ethernet connections are provided on RJ45 jacks and are configured by the Dante module to operate as a hub/switch.

Figure 34 shows the typical interconnection of the 2 cards to provide a single Ethernet link to the DAW computer. It is also possible to come out of the console with 2 separate Ethernet cables (one from each card) and use an external hub/switch to connect the DAW computer. As previously mentioned the console will appear as 2 devices on the Dante network. It is recommended that a Gigabit Ethernet (1000-BASE-T) network is used, with a Gigabit Ethernet port on the DAW computer and a Gigabit Ethernet external switch (if used), all connected with high quality CAT5E or CAT6 cables.

Figure 34: NETWORK INTERCONNECTION OF CONVERTER/DANTE CARDS

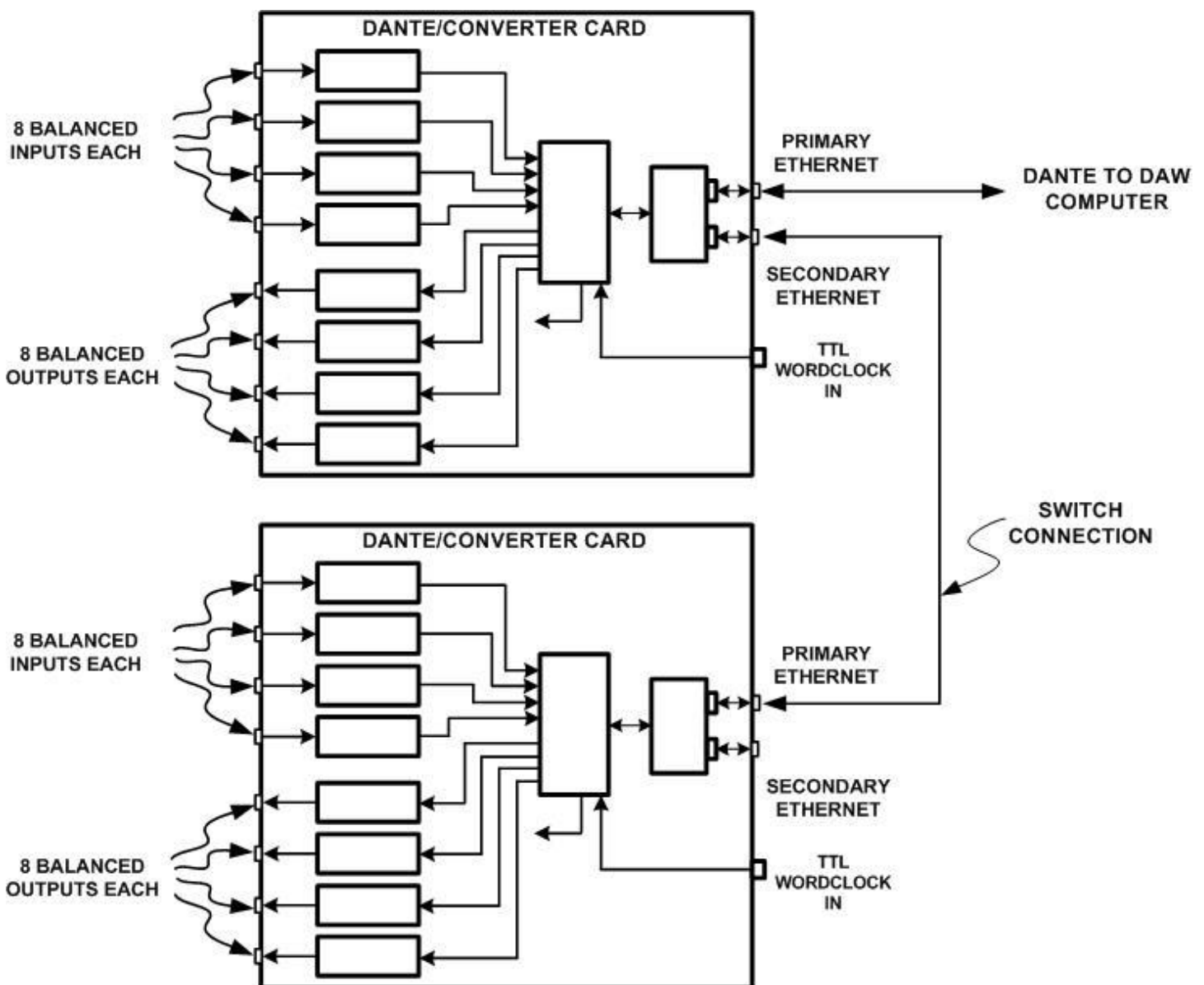

3.4.4 Dante Wordclock

On Dante networks, almost any device on the network may be specified in the Dante network management software as the wordclock master. In typical setups the console might be a wordclock slave to another device on the Dante network such as an I/O device, or might itself be the wordclock master.

Should the user choose to have the console as the network clock master, it can be done in 2 ways:

- one of the Dante interface cards can be designated the network wordclock master using its internal clock
- an external TTL wordclock can be supplied to one of the converter/Dante cards which would then be specified as network wordclock master. This option is preferred if your studio has a highly accurate wordclock source available.

A BNC connector is provided on the converter/Dante card for connection of a TTL wordclock. While not absolutely standardized, guidelines for TTL wordclocks can be found in AES standard AES-11. The recommendations specify 75 ohm coax cabling and terminations. This connector is unterminated, so the required 75 ohm terminating resistor would have to be supplied externally. Note that there are 2 types of BNC connectors, with 75 and 50 ohm impedances. The 75 ohm type is used on the converter/Dante card and should be connected using the matching type of connector, coax cable and terminating resistor.

If designating the console as wordclock master on the Dante network, both converter/Dante cards need not be supplied with the external wordclock. It is sufficient to apply wordclock to one converter/Dante card.

- if supplying external wordclock to one converter/Dante card, it doesn't matter which one is chosen as long as it is selected as wordclock master in the Dante network management software
- the other converter/Dante card is set up as a wordclock slave on the Dante network

Figure 35 shows a screen shot of the Dante Controller clocking page for an example Dante setup. Dante interface "HA-32CI-046f9e" is one of the console converter/Dante cards and is designated the wordclock master. In this example it is supplied with an external TTL wordclock ("Enable Sync to External"). Unchecking this box will use the internal clock in the Dante interface hardware as the wordclock master, as shown in Figure 36.

Note that computers running DAW software and using Virtual Soundcard software for the Dante network interface cannot be wordclock masters and are wordclock slaves by default. These are indicated by the "Slave Only" indications in the figures. In this example "WAYNETHOR" is a computer running the target DAW.

Figure 35: DANTE WORDCLOCK SETUP- EXTERNAL CLOCK

The screenshot shows the Dante Controller Network View interface. The Grand Master Clock is identified as HA-32CI-046f9e. The 'Clock Status' tab is active, displaying a table of device configurations. The HA-32CI-046f9e device is configured as the Master with an External Clock source, and its 'Preferred Master' and 'Enable Sync To External' checkboxes are checked.

Device Name	Sync	Mute	Clock Source	Domain Status	Primary Status	Secondary Status	AES67 Status	Preferred Master	Enable Sync To External
BKLYN-II-0b672e	<input checked="" type="checkbox"/>		Dante	N/A	Slave	N/A	N/A	<input type="checkbox"/>	<input type="checkbox"/>
BknII-0b6568	<input checked="" type="checkbox"/>		Dante	N/A	Slave	N/A	N/A	<input type="checkbox"/>	<input type="checkbox"/>
Dell-Win10	<input checked="" type="checkbox"/>		Dante	N/A	Slave	N/A	N/A	Slave Only	N/A
HA-32CI-046f9e	<input checked="" type="checkbox"/>		External Clock	N/A	Master	N/A	N/A	<input checked="" type="checkbox"/>	<input checked="" type="checkbox"/>
HA-PM-0470b8	<input checked="" type="checkbox"/>		Dante	N/A	Slave	N/A	N/A	<input type="checkbox"/>	N/A
TODD-ha-32vi-0b693e	<input checked="" type="checkbox"/>		Dante	N/A	Slave	N/A	N/A	<input type="checkbox"/>	N/A
WAYNETHOR	<input checked="" type="checkbox"/>		Dante	N/A	Slave	N/A	N/A	Slave Only	N/A
Win10-TestingOffice	<input checked="" type="checkbox"/>		Dante	N/A	Slave	N/A	N/A	Slave Only	N/A

Figure 36: DANTE WORDCLOCK SETUP- INTERNAL CLOCK

The screenshot shows the Dante Controller Network View interface. The Grand Master Clock is identified as HA-32CI-046f9e. The 'Clock Status' tab is active, displaying a table of device configurations. The HA-32CI-046f9e device is configured as the Master with a Dante clock source, and its 'Preferred Master' checkbox is checked.

Device Name	Sync	Mute	Clock Source	Domain Status	Primary Status	Secondary Status	AES67 Status	Preferred Master	Enable Sync To External
BKLYN-II-0b672e	<input checked="" type="checkbox"/>		Dante	N/A	Slave	N/A	N/A	<input type="checkbox"/>	<input type="checkbox"/>
BknII-0b6568	<input checked="" type="checkbox"/>		Dante	N/A	Slave	N/A	N/A	<input type="checkbox"/>	<input type="checkbox"/>
Dell-Win10	<input checked="" type="checkbox"/>		Dante	N/A	Slave	N/A	N/A	Slave Only	N/A
HA-32CI-046f9e	<input checked="" type="checkbox"/>		Dante	N/A	Master	N/A	N/A	<input checked="" type="checkbox"/>	<input type="checkbox"/>
HA-PM-0470b8	<input checked="" type="checkbox"/>		Dante	N/A	Slave	N/A	N/A	<input type="checkbox"/>	N/A
TODD-ha-32vi-0b693e	<input checked="" type="checkbox"/>		Dante	N/A	Slave	N/A	N/A	<input type="checkbox"/>	N/A
WAYNETHOR	<input checked="" type="checkbox"/>		Dante	N/A	Slave	N/A	N/A	Slave Only	N/A
Win10-TestingOffice	<input checked="" type="checkbox"/>		Dante	N/A	Slave	N/A	N/A	Slave Only	N/A

3.4.5 Dante Channel Assignments

The console is supplied with the Dante connections prewired. The following tables list the standard Dante connections provided.

As mentioned earlier in this document, these assignments can be rearranged or removed if the user desires by recabling or removing the connections from the console motherboards to the Dante I/O boxes on the underside of the console. The installed arrangement of the cabling is shown in [Figure 32](#).

Additionally, the Dante Controller software from [permut](#) permits renaming of the Dante signals on the Dante Controller router page. This is left to the user if the standard signal naming needs to be changed to suit a particular studio installation. See the [Dante Controller User Guide \(Reference 3\)](#).

Table 1: STANDARD DANTE CHANNEL ASSIGNMENTS

Channel Section			
Channel Playback Inputs	Dante Channel	Channel Direct Outputs	Dante Channel
Channel 1	IN 1	Channel 1	OUT 1
Channel 2	IN 2	Channel 2	OUT 2
Channel 3	IN 3	Channel 3	OUT 3
Channel 4	IN 4	Channel 4	OUT 4
Channel 5	IN 5	Channel 5	OUT 5
Channel 6	IN 6	Channel 6	OUT 6
Channel 7	IN 7	Channel 7	OUT 7
Channel 8	IN 8	Channel 8	OUT 8
Channel 9	IN 9	Channel 9	OUT 9
Channel 10	IN 10	Channel 10	OUT 10
Channel 11	IN 11	Channel 11	OUT 11
Channel 12	IN 12	Channel 12	OUT 12
Channel 13	IN 13	Channel 13	OUT 13
Channel 14	IN 14	Channel 14	OUT 14
Channel 15	IN 15	Channel 15	OUT 15
Channel 16	IN 16	Channel 16	OUT 16
Channel 17	IN 17	Channel 17	OUT 17
Channel 18	IN 18	Channel 18	OUT 18
Channel 19	IN 19	Channel 19	OUT 19
Channel 20	IN 20	Channel 20	OUT 20
Channel 21	IN 21	Channel 21	OUT 21
Channel 22	IN 22	Channel 22	OUT 22
Channel 23	IN 23	Channel 23	OUT 23
Channel 24	IN 24	Channel 24	OUT 24
Channel 25	IN 25	Channel 25	OUT 25
Channel 26	IN 26	Channel 26	OUT 26
Channel 27	IN 27	Channel 27	OUT 27
Channel 28	IN 28	Channel 28	OUT 28
Channel 29	IN 29	Channel 29	OUT 29
Channel 30	IN 30	Channel 30	OUT 30
Channel 31	IN 31	Channel 31	OUT 31
Channel 32	IN 32	Channel 32	OUT 32

Table 2: STANDARD DANTE MASTER SECTION ASSIGNMENTS

Master Section			
Master Section Inputs	Dante Channel	Master Section Outputs	Dante Channel
Dante In Cue/Matrix 1 Left	IN 1	Bus 1	OUT 1
Dante In Cue/Matrix 1 Right	IN 2	Bus 2	OUT 2
Dante In Cue/Matrix 2 Left	IN 3	Bus 3	OUT 3
Dante In Cue/Matrix 2 Right	IN 4	Bus 4	OUT 4
Dante In Cue/Matrix 3 Left	IN 5	Bus 5	OUT 5
Dante In Cue/Matrix 3 Right	IN 6	Bus 6	OUT 6
Dante In Monitor Left	IN 7	Bus 7	OUT 7
Dante In Monitor Right	IN 8	Bus 8	OUT 8
Surround Dante In 1 (Left Front)	IN 9	Main Mix Out L	OUT 9
Surround Dante In 2 (Right Front)	IN 10	Main Mix Out R	OUT 10
Surround Dante In 3 (Center Front)	IN 11	Cue/Matrix 1 Out Left	OUT 11
Surround Dante In 4 (Sub)	IN 12	Cue/Matrix 1 Out Right	OUT 12
Surround Dante In 5 (Left Side)	IN 13	Cue/Matrix 2 Out Left	OUT 13
Surround Dante In 6 (Right Side)	IN 14	Cue/Matrix 2 Out Right	OUT 14
Surround Dante In 7 (Left Rear)	IN 15	Cue/Matrix 3 Out Left	OUT 15
Surround Dante In 8 (Right Rear)	IN 16	Cue/Matrix 3 Out Right	OUT 16
Surround Dante In 9 (LF Overhead)	IN 17	uncommitted	OUT 17
Surround Dante In 10 (RF Overhead)	IN 18	uncommitted	OUT 18
Surround Dante In 11 (LR Overhead)	IN 19	uncommitted	OUT 19
Surround Dante In 12 (RR Overhead)	IN 20	uncommitted	OUT 20
uncommitted	IN 21	uncommitted	OUT 21
uncommitted	IN 22	uncommitted	OUT 22
uncommitted	IN 23	uncommitted	OUT 23
uncommitted	IN 24	uncommitted	OUT 24
uncommitted	IN 25	uncommitted	OUT 25
uncommitted	IN 26	uncommitted	OUT 26
uncommitted	IN 27	uncommitted	OUT 27
uncommitted	IN 28	uncommitted	OUT 28
uncommitted	IN 29	uncommitted	OUT 29
uncommitted	IN 30	uncommitted	OUT 30
uncommitted	IN 31	uncommitted	OUT 31
uncommitted	IN 32	uncommitted	OUT 32

4.0 Functional Description and Signal Flow

4.1 Channel Strip Block Diagram

Refer to [Figure 37](#) which shows the block diagram of the Channel Strip.

There are 4 primary signal inputs to the channel strip. These are:

- Microphone input: This input is transformer coupled as standard. Phantom power and 20dB pad are located ahead of the transformer. The preamp has adjustable gain of +20 to +70 dB, so minimum gain setting with the pad engaged can accept a +4 input.
- Line input (local)
- Instrument Input (bussed from Master module)
- Playback from Dante input

Additionally there is the local Return input, its signal is summed directly to the Return bus and does not appear anywhere else on the channel strip.

Input selection provides either the microphone input, or any combination of the 3 line level inputs summed together. There is a gain trim option for the composite post-summing line level input. After the polarity reverse option, the selected input is the final channel strip input source and also drives the channel insert send.

The channel strip input source drives the channel 4-band EQ and filters, with insert option ahead of the EQ. Aux sends are always fed post EQ-filters but pre/post feed option differs depending on whether the channel strip is in mixdown mode or monitor inline mode:

- In mixdown mode, the pre/post Aux send option selects pre or post fader feed, always post EQ and filters. Pre/post selection for the mono Aux sends is selected in pairs, 1-2 and 3-4. The Stereo Aux send has individual pre/post selection with its own panner. Note that the main channel mute is post fader and does NOT mute the AUX sends if they are selected PRE.
- In monitor inline mode, all Aux sends are always fed pre fader from the post EQ and filters point. Note that the main channel mute does NOT mute the AUX sends in this mode.
- The Dante Playback input can always be selected as an additional source to the Stereo Aux. It is summed with the channel signal ahead of the level and pan controls.

Channel fader, main channel mute, main channel panning and bus/main mix assign are fed differently depending on whether the channel strip is in mixdown or monitor inline mode:

- In mixdown mode, the channel fader is fed from the post EQ-filters point
- In monitor inline mode the channel fader is fed from the Dante Playback input

The fader can be disabled and the channel level hard set to the 0dB reference level (-10 dB below fader max) using the 0dB button.

Eight group buses are assigned post-pan with individual assign buttons, odd buses from pan left and even buses from pan right if the Bus Pan button is engaged. If Bus Pan is not engaged, all buses are fed from the pre-pan post-mute point.

The main stereo mix is assigned using the Main Mix button, post pan if the Mix Pan button is engaged. Note that Bus Pan and Mix Pan are independent.

Solo is always of the Solo-In-Place type, fed post pan. If the channel is assigned to the main stereo mix, solo will be from the Main Mix assign point and will follow the pan setting if Mix Pan is engaged. If the channel is NOT assigned to the main stereo mix, solo will be from the bus assign point and will follow the pan setting if Bus Pan is engaged.

Figure 37: CHANNEL STRIP BLOCK DIAGRAM

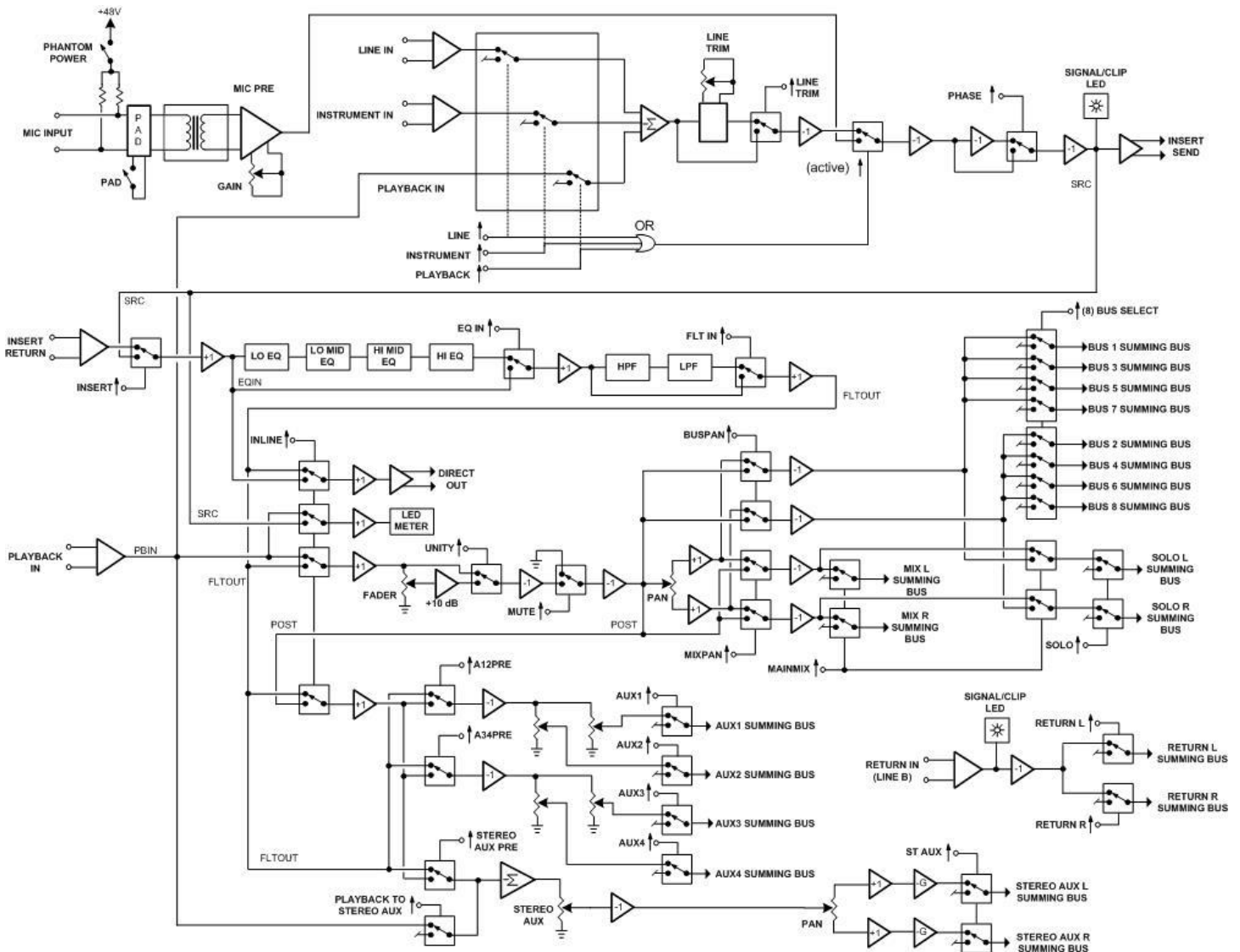

4.1.1 Channel Strip Signal Flow – Mixdown Mode

Figure 38 shows the channel strip signal flow in mixdown mode.

In this mode the signal flow path is entirely conventional and familiar: Inputs -> mic/line select -> phase -> insert -> EQ -> HPF/LPF -> fader -> mute -> aux sends pre or post fader -> pan -> bus and main mix assign. Direct out is taken from ahead of the EQ, after the insert point.

Unique features are the ability to sum 3 line sources, and the ability to sum the playback input into the stereo AUX.

Figure 38: CHANNEL STRIP SIGNAL FLOW - MIXDOWN MODE

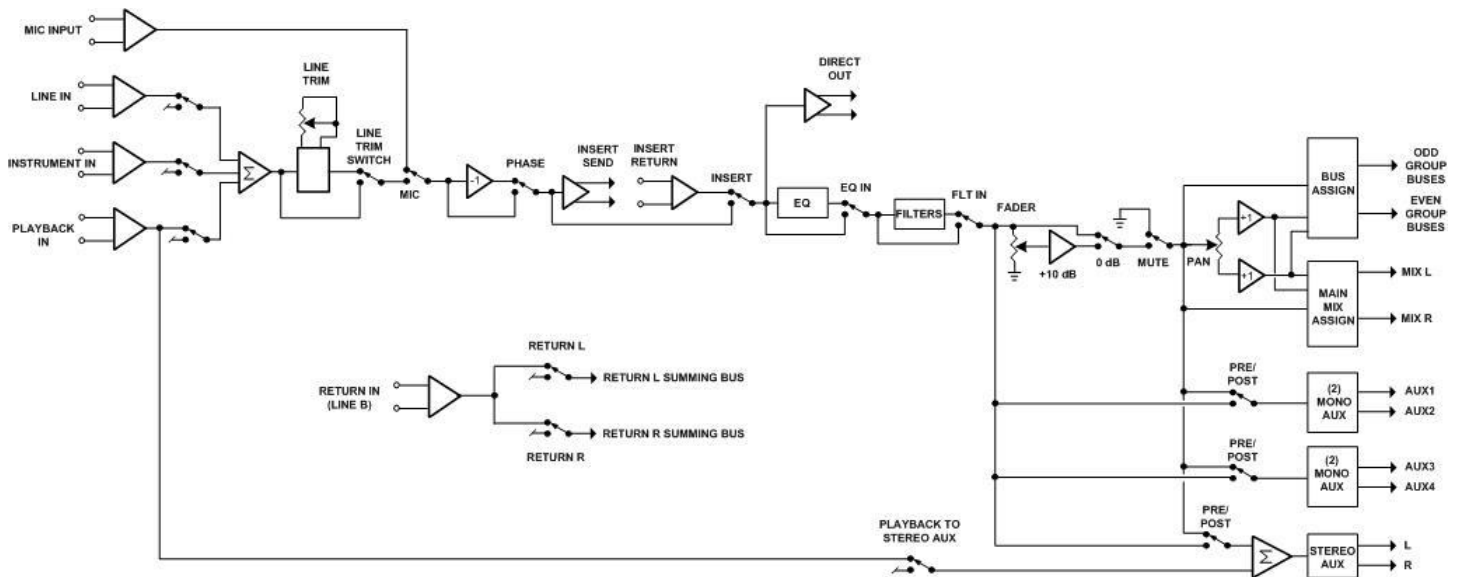

4.1.2 Channel Strip Signal Flow – Monitor Inline Mode

With the Inline button engaged, the channel strip is put into monitor inline mode, indicated by an unmistakable blue LED. Figure 39 shows the channel strip signal flow in monitor inline mode.

In this mode the fader -> mute -> pan -> bus and main mix assign signal path is fed from the channel's playback input. The inputs -> mic/line select -> phase -> insert -> EQ -> HPF/LPF signal path is the same as in mixdown mode. All Aux sends are fed from the filters output point, as is the direct output. As before, the playback input may also be summed into the stereo AUX.

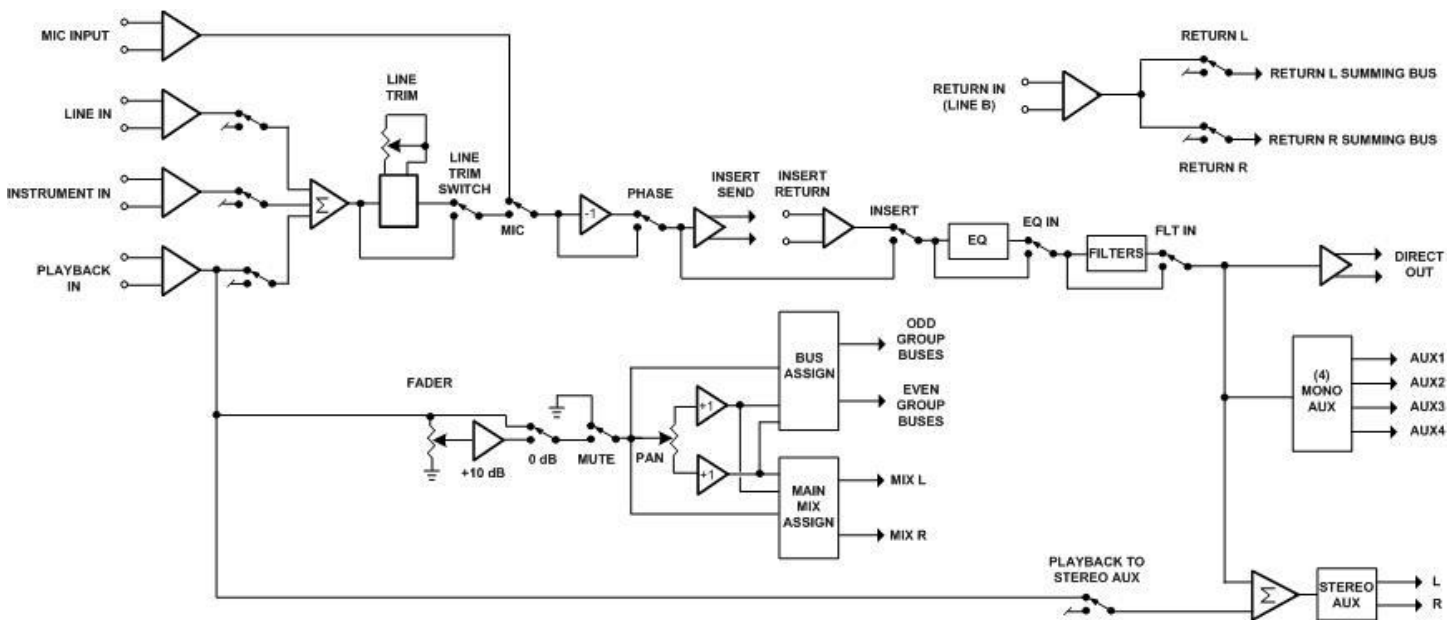
Figure 39: CHANNEL STRIP SIGNAL FLOW – MONITOR INLINE MODE

4.1.3 Return Mix

In either channel strip configuration the Return mix input is always available, its dedicated and separate input targets the stereo Return mix bus and appears nowhere in the main signal flow path of the channel strip.

The Return Mix is a line level input, one input per channel strip. There are independent assign buttons for left and right sends to the Return mix bus, but no level control or other controls. It is assumed that individual level control building a Return mix will be done at the source to these inputs – DAW, external mic pre, another console etc.

See Section [4.3.2](#) for further details about the Return Mix.

4.2 Bus Module 1-6 Block Diagram

Dual bus modules for buses 1-2, 3-4 and 5-6 are all the same, and each feature a single Cue/Matrix section with significant flexibility. The Cue/Matrix section may be used to build headphone/cue mixes, matrix/sound effects outputs, or any application requiring a mix separate from the main console mix. The Cue/Matrix mix is stereo and may be built up from as many as 18 sources. [Figure 40](#) shows the block diagram of the Bus 1-6 with Cue/Matrix module.

Figure 40: BUS MODULE 1-6 BLOCK DIAGRAM

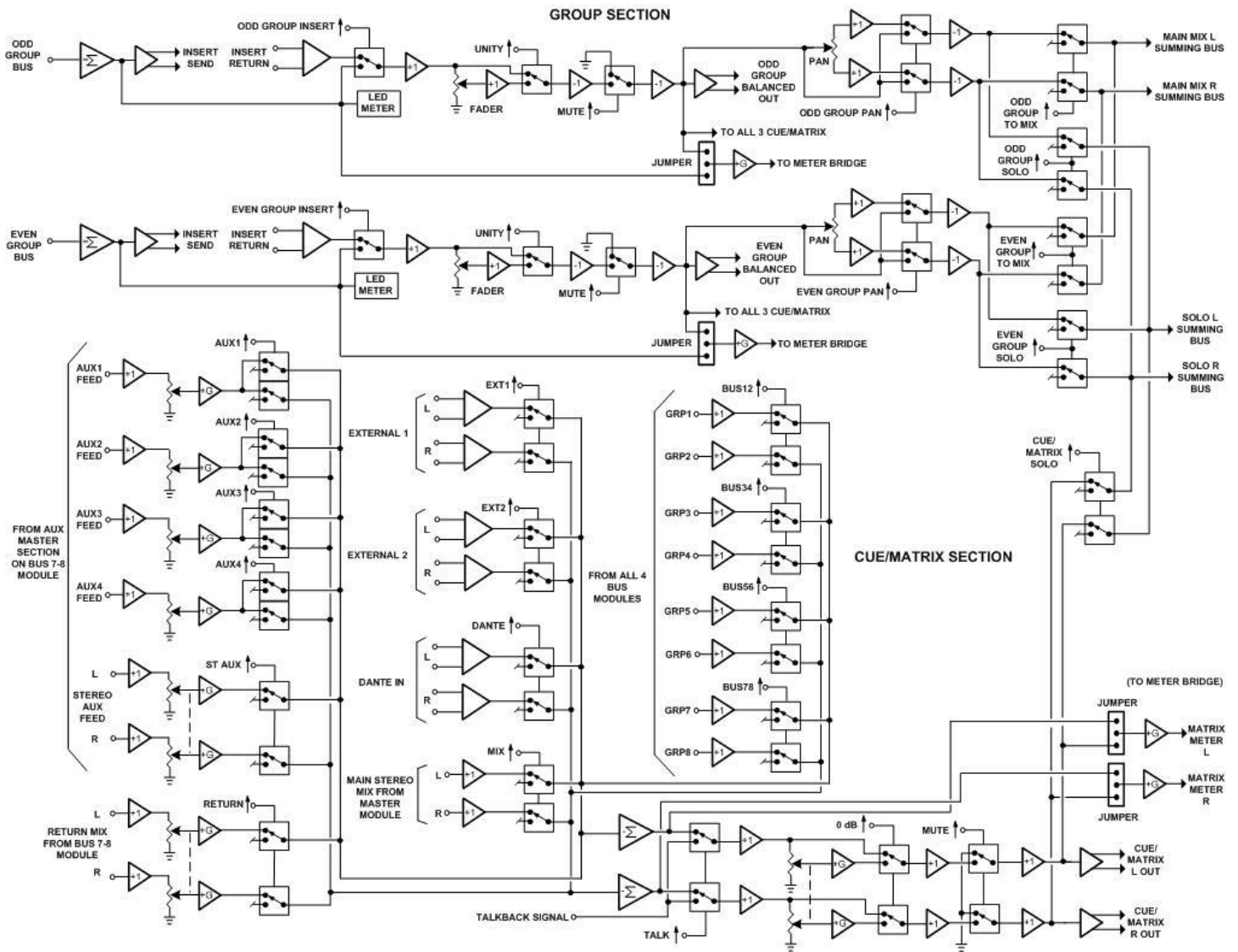

4.2.1 Group Bus Section

The two Bus masters have a conventional signal flow: summing -> insert -> fader -> mute -> output -> pan to main stereo mix. The LED meter reads at the bus summing point. The analog meters on the console meter bridge may be jumper selected to read either the bus summing point or the post fader/post mute point ahead of the panner.

4.2.2 Cue/Matrix Section

The Cue/Matrix section creates a distinct and separate stereo mix from all other *bus* sources and several external inputs to the console. Sources to each Cue/Matrix mix are:

- 4 mono Aux sends, with individual level controls, equal feed to Cue/Matrix L-R
- the stereo Aux send, with individual level control
- the stereo Return mix, with individual level control
- the 8 group buses, in odd/even pairs to Cue/Matrix L-R, without individual level control (note, these feeds are post bus fader)
- the main stereo mix, without individual level control (note, these feeds are post main mix fader)
- two external L-R pairs of analog inputs, without individual level control
- dedicated stereo pair from the Dante interface, without individual level control
- internal talkback

It is expected that the 4 sources above without individual level control will have some method of controlling their level externally.

Following the Cue/Matrix summing, the signal flow path is talkback inject -> fader -> mute -> output. Jumpers select the signal sources to the analog meter bridge, either immediately after the summer before the talkback inject, or the Cue/Matrix output.

Solo for both Groups and Cue/Matrix is taken from the bus output, post fader/post panner.

4.2.3 Talkback

The Cue/Matrix buses are intended to provide a convenient way to produce headphone or cue mixes. As such, it is practical to provide a talkback signal to the Cue/Matrix. A non-latching TALK button routes the talkback signal into the Cue/Matrix output. The Cue/Matrix mix is interrupted when talkback is active. All 3 Cue/Matrix outputs may be simultaneously fed the talkback using the ALL TALK button at the talkback master on the Bus 7-8 module, see Section [4.3.3](#).

4.3 Bus Module 7-8 Block Diagram

[Figure 41](#) shows the block diagram of the Bus 7-8 module. Like the Bus modules for groups 1-6, this module has bus master section for 2 group buses, identical to the others. Instead of having the Cue/Matrix master, this module has the master sections for all 5 Aux sends and the Return mix. Additionally, it has the talkback section including built-in electret microphone.

Figure 41: BUS MODULE 7-8 BLOCK DIAGRAM

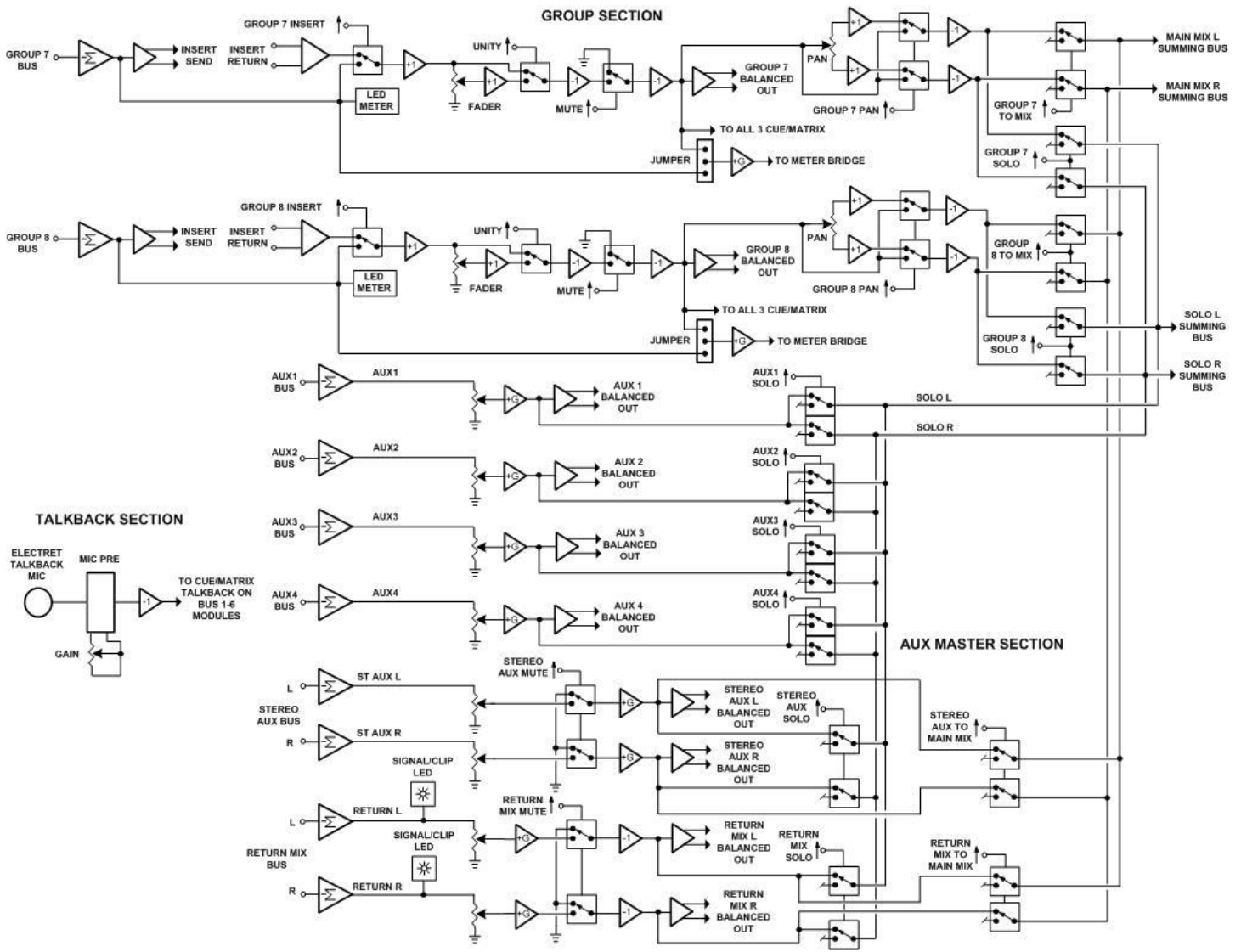

4.3.1 Group Bus Section

The two Bus masters have a conventional signal flow: summing -> insert -> fader -> mute -> output -> pan to main stereo mix. The LED meter reads at the bus summing point. The analog meters on the console meter bridge may be jumper selected to read either the bus summing point or the post fader/post mute point ahead of the panner.

As with the other group modules, solo for Group buses is always solo in place post pan and post level control.

4.3.2 Aux and Return Mix Master Sections

The 4 mono Aux sends each have a master output level control and balanced output. The Stereo Aux has individual output level controls for its left and right balanced outputs. Additionally, the stereo Aux can be assigned post level controls to the main stereo mix. A mute button is provided which mutes both the balanced outputs and the send to the main stereo mix.

Similarly, the Return Mix master has individual output level controls for its left and right balanced outputs and may also be assigned post level control to the main stereo mix. A mute button is provided which mutes both the balanced outputs and the send to the main stereo mix.

Solo for the Aux masters and the Return master is post level control. Mono Aux masters feed both left and right solo buses. The stereo Aux and Return master feed the solo bus stereo and post mute.

4.3.3 Talkback

The Talkback facility features a built-in electret microphone with level control, feeding the Cue/Matrix sections on the other 3 Group/Bus modules. The microphone can be routed simultaneously to all 3 Cue/Matrix outputs by pressing the ALL TALK button, or to each Cue/Matrix section individually using their local TALK buttons (see Section [4.2.3](#)).

4.4 Master Module Block Diagram

The block diagram of the Master module is shown in [Figure 42](#). This module contains the following:

- main stereo mix bus
- instrument input and preamp
- comprehensive Monitor section with:
 - 12 speaker outputs with corresponding inputs capable of monitoring 11.1/7.1.4 surround (typically from the DAW over Dante)
 - 2 stereo external analog inputs to the monitor path
 - stereo Dante input to the monitor path
 - solo appears on main L-R speaker outputs
 - headphone output with level control, derived from main L-R speaker outputs
 - alternate main front L-R speaker outputs for use with different monitors, nearfields etc.
 - separate level controls for main and alternate main L-R speaker outputs
 - monitor Dim button with Dim level control
 - master monitor level control and Mute button

4.4.1 Main Stereo Mix Section

The main stereo mix bus section is similar to the Group buses. The signal flow is conventional: summing -> insert -> fader -> mute -> output. The LED meter may be jumper selected to read at the bus summing point or post mute at the balanced driver input. The main L-R analog meters on the meter bridge read at the balanced driver output.

A unique feature on the main L-R outputs is the ability to select either electronically balanced line driver or a Jensen transformer balanced output. The transformer select button shown in [Figure 19](#) is used.

4.4.2 Instrument/Mic Input Section

Unique to the 32Classic console is the centralized mic/instrument input on the master module. This provides a convenient way to record instrument tracks, vocals, voiceovers, last minute overdubs and what have you right at the console.

This input is accessed through a combo XLR connector on the master module front panel. The mic preamp is identical to the mic pre on the channel strips, except without the transformer. Phantom power and 20dB input pad are provided on the mic input enabling use of your favourite condenser mic or DI box. A signal present/clip LED provides basic level indication.

The 1/4" input of the combo connector accesses an instrument preamp for initial preprocessing, and the signal is then passed through the microphone preamp. Either the mic or instrument input (but not both at once) may be selected as input to the mic preamp. Following the preamp the resulting signal is electronically balanced and bussed across the console. The signal may be selected as input to any channel strip, or directly to the main stereo mix.

Figure 42: MASTER MODULE BLOCK DIAGRAM

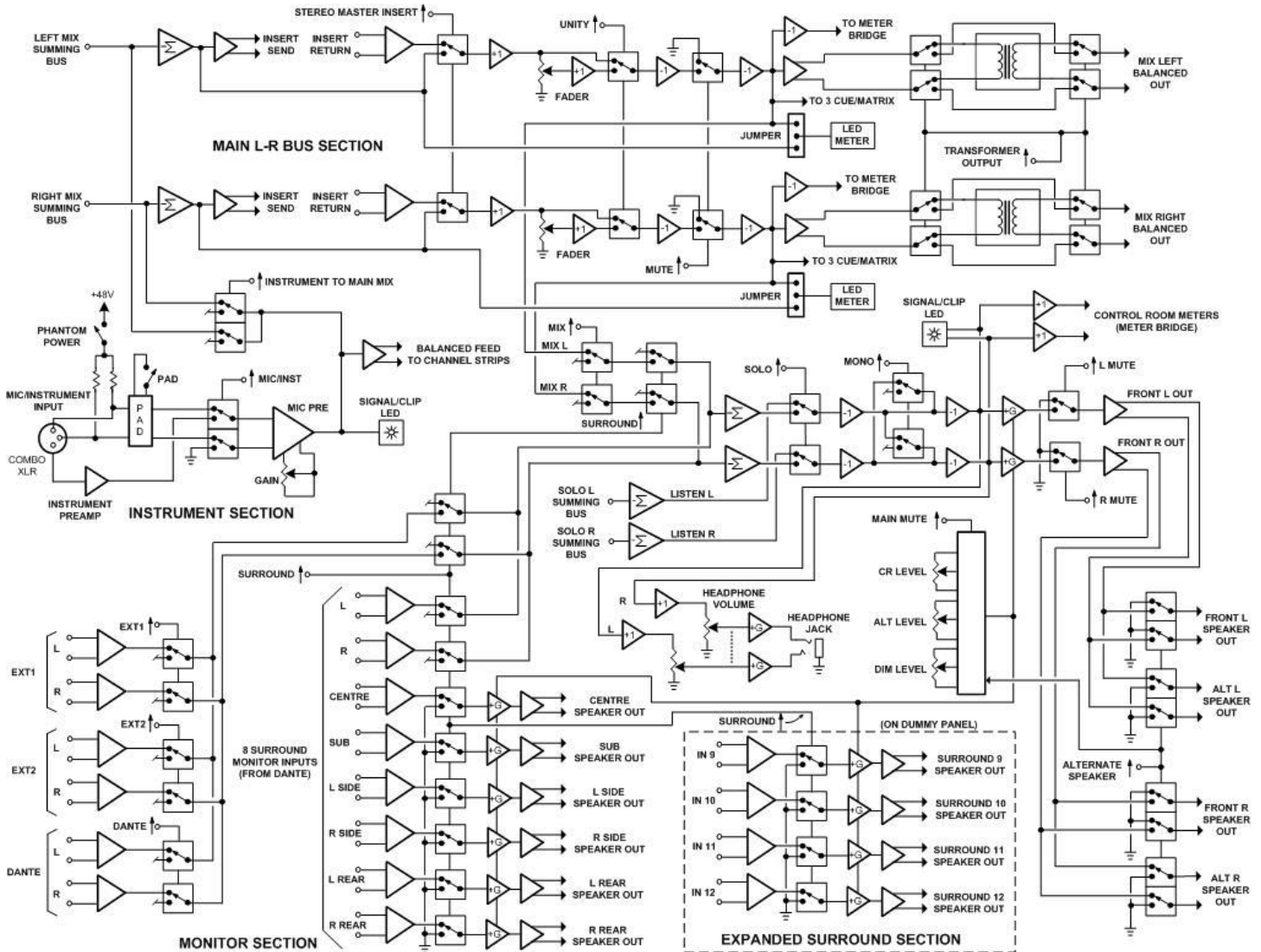

4.4.3 Monitor Section

The monitor section with controls shown in [Figure 21](#) provides a comprehensive monitoring capability to headphones or a stereo monitor pair with alternate/nearfield monitor selection at Left and Right front. Additionally, 11.1/7.1.4 surround monitoring is possible from 12 inputs from the Dante interface to corresponding speaker outputs.

The left and right front monitor path forms the main part of the control room monitoring capabilities. The red MIX button provides monitoring of the console main stereo mix. Left and Right speaker outputs have individual MUTE buttons. A MONO button provides checking for mono compatibility. Also provided is a pair of alternate outputs for nearfields or other alternate monitors. Separate level controls are provided for both sets of L-R monitor outputs so that monitoring levels may be matched. The DIM button drops the level on all monitors simultaneously to a level adjusted with the DIM LEVEL control.

As shown in [Figure 22](#) the monitoring path has an illuminated master MUTE button and control room monitor level control. These control ALL 12 monitor outputs simultaneously. They are placed at the bottom of the Master strip in order that their expected frequent use will not risk inadvertently bumping the master mix fader or other controls in the main mix path.

Soloing appears in the main left and right front monitors. When in solo, all other sources to these monitors are disconnected. See [Chapter 5.0](#) for a detailed description of solo operation.

4.4.3.1 External Monitoring

The main left and right front speaker outputs can also monitor 3 external stereo inputs in addition to the main mix, selectable with the buttons shown in [Figure 21](#). External 1 and External 2 are stereo line level analog inputs. A stereo pair of channels from the Dante interface may also be selected. These are not mutually exclusive, selecting more than one of these inputs at once will sum all into a composite monitor signal.

Possible uses for these inputs might be for stereo playback from 2-track analog tape recorders through the External inputs, and DAW monitor or main mix out through the Dante input.

4.4.3.2 Surround Monitoring

The Surround monitoring capability is provided so that surround mixes created in your DAW can be monitored through the console. Surround monitoring is engaged with the SUR button shown in [Figure 21](#). When engaged the main front left and right outputs plus 10 additional speaker feed outputs are fed with 12 dedicated surround inputs from the Dante interface, permitting monitoring of 11.1 or 7.1.4 surround. Any front L-R monitor feeds from main mix, external, or the Dante stereo input are removed and replaced with the surround Left Front and Right Front sources. Additionally, solo operation in the Left front and Right front monitors is inhibited when in Surround monitoring.

[Figure 43](#) shows the monitor path signal flow when Surround mode is engaged. Note that even though soloing is inhibited, the alternate Left and Right front monitors may still be engaged instead of the main front monitors. Also the MONO switch for the Left and Right front monitors continues to function, as do the individual LF and RF Mute buttons. [Table 3](#) shows the typical assignments to the surround monitor outputs.

If Surround mode is NOT selected, only the main Left and Right front monitors are active, the other 10 surround outputs are silenced.

Figure 43: MONITOR SIGNAL FLOW IN SURROUND MODE

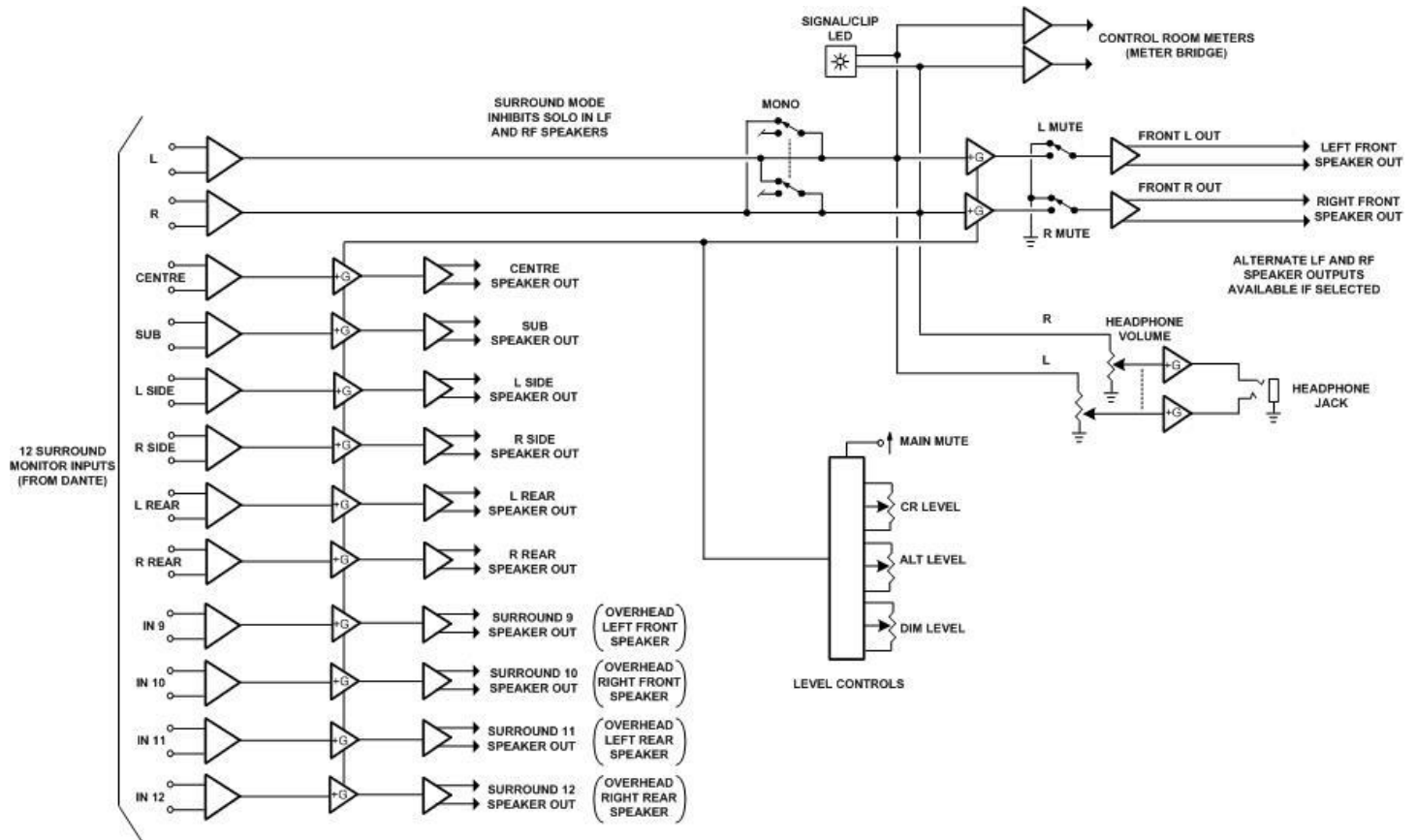

Table 3: TYPICAL SURROUND MONITOR ASSIGNMENTS

SURROUND IN/SPEAKER OUT	TYPICAL USE	NOTES
1	LEFT FRONT	SOLO HERE, DUPLICATED ON ALT MONITOR OUTPUT
2	RIGHT FRONT	
3	CENTER FRONT	
4	SUBWOOFER	
5	LEFT SIDE	
6	RIGHT SIDE	
7	LEFT REAR	
8	RIGHT REAR	
9	LEFT FRONT OVERHEAD	
10	RIGHT FRONT OVERHEAD	
11	LEFT REAR OVERHEAD	
12	RIGHT REAR OVERHEAD	

4.4.3.3 Alternate Monitor Output

The Alternate monitor outputs are provided to facilitate use of an alternate pair of front monitor speakers, such as a pair of nearfields. As shown in Section [2.3.4.7](#) and [Figure 21](#) the alternate output is selected with the ALT button in the monitor section. The Alternate monitor output is a copy of the main Left Front and Right Front monitor outputs, even when Surround mode is selected. Soloing, mono and mute functions operate on the alternate output just as on the primary Left Front and Right Front monitor outputs. The Alternate monitor output has its own level control that can be used to match the level to that of the main monitors.

5.0 Solo Operation

All solo functions on the 32Classic are stereo Solo-In-Place (SIP), post pan and post fader. A Pre Fade Listen (PFL) mode is not available.

In general the solo points in the signal paths vary depending on signal path and source signal selections. This is particularly true in the channel strip module. The following sections will detail the solo operation for each module type.

5.1 Solo in the Channel Strip Modules

Figure 44 shows a simplified version of the soloing path in the channel strip. The soloing point is always post fader, mute and pan. Note the following:

- the solo bus will be fed from either the bus route path or the main mix route path, depending on whether routing to the main mix is engaged. If routed to the main mix, solo feed will come from the main mix path. If the main mix is not routed, solo feed will come from the bus feed path. If both buses and the main mix are routed, the main mix path has priority and solo feed will be from the main mix path.
- solo feeds in both paths are post panner and pan select. If the PAN button is not selected in the active solo path, the solo bus will be fed equally to both sides by the pre-pan signal.

Figure 44: CHANNEL STRIP SOLO

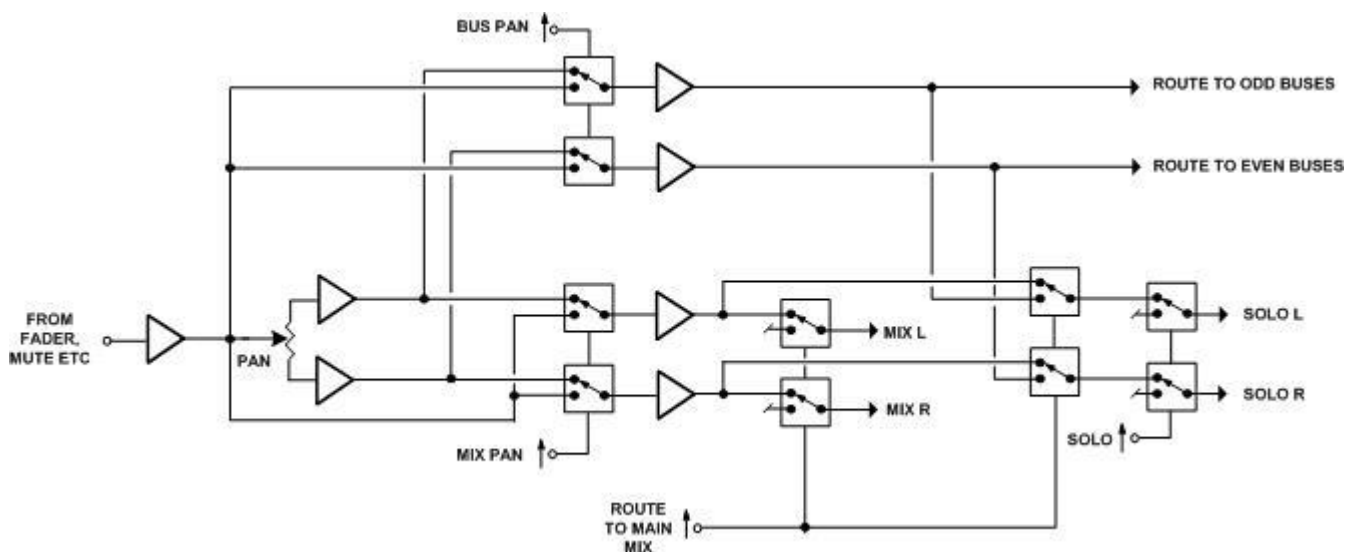

5.2 Solo in the Group/Cue-Matrix Modules

Figure 45 shows a simplified version of the soloing path in each of the Bus 1-6 modules. As on the channel strips the solo points are post fader-mute-pan in each bus path, and post fader-mute in the Cue/Matrix path.

- left and right sides of the Solo bus will be fed equally with the bus signal if the Bus Pan is not engaged.
- left and right sides of the Solo bus will be fed with Cue/Matrix left/right directly, post level control

Figure 45: GROUP 1-6 SOLO

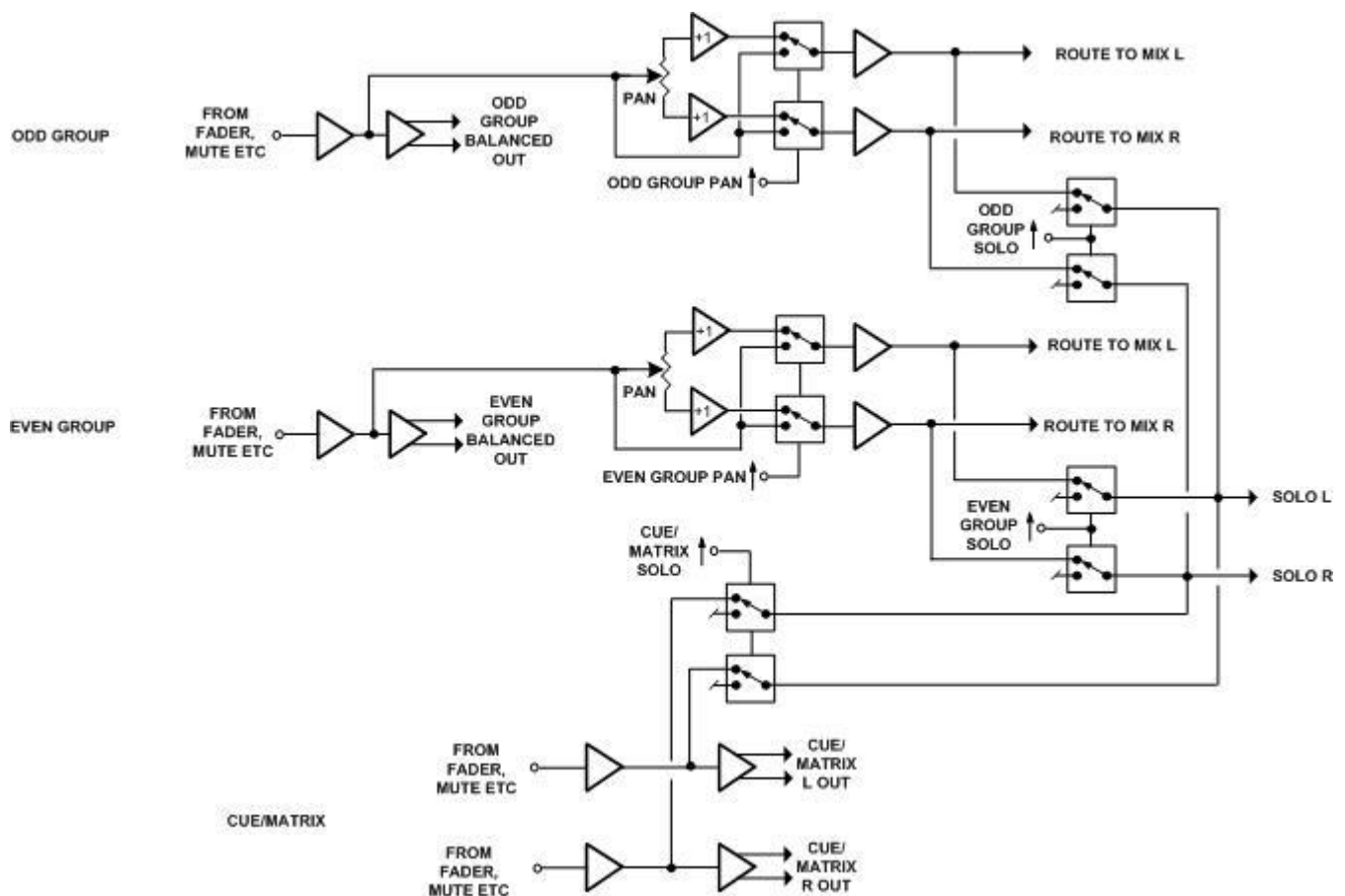

5.3 Solo in the Group/Aux- Master Module

Figure 46 shows a simplified version of the soloing path in the Bus 7-8 module.

- Group soloing is the same as on the Group 1-6 modules, the solo points are post fader-mute-pan in each bus path. Left and right sides of the Solo bus will be fed equally with the bus signal if the Bus Pan is not engaged.
- The 4 mono Aux sends feed the stereo solo bus post-level control equally to both sides.
- The stereo Aux and the Return mix each feed the stereo solo bus directly, post level control.

Figure 46: GROUP 7-8 SOLO

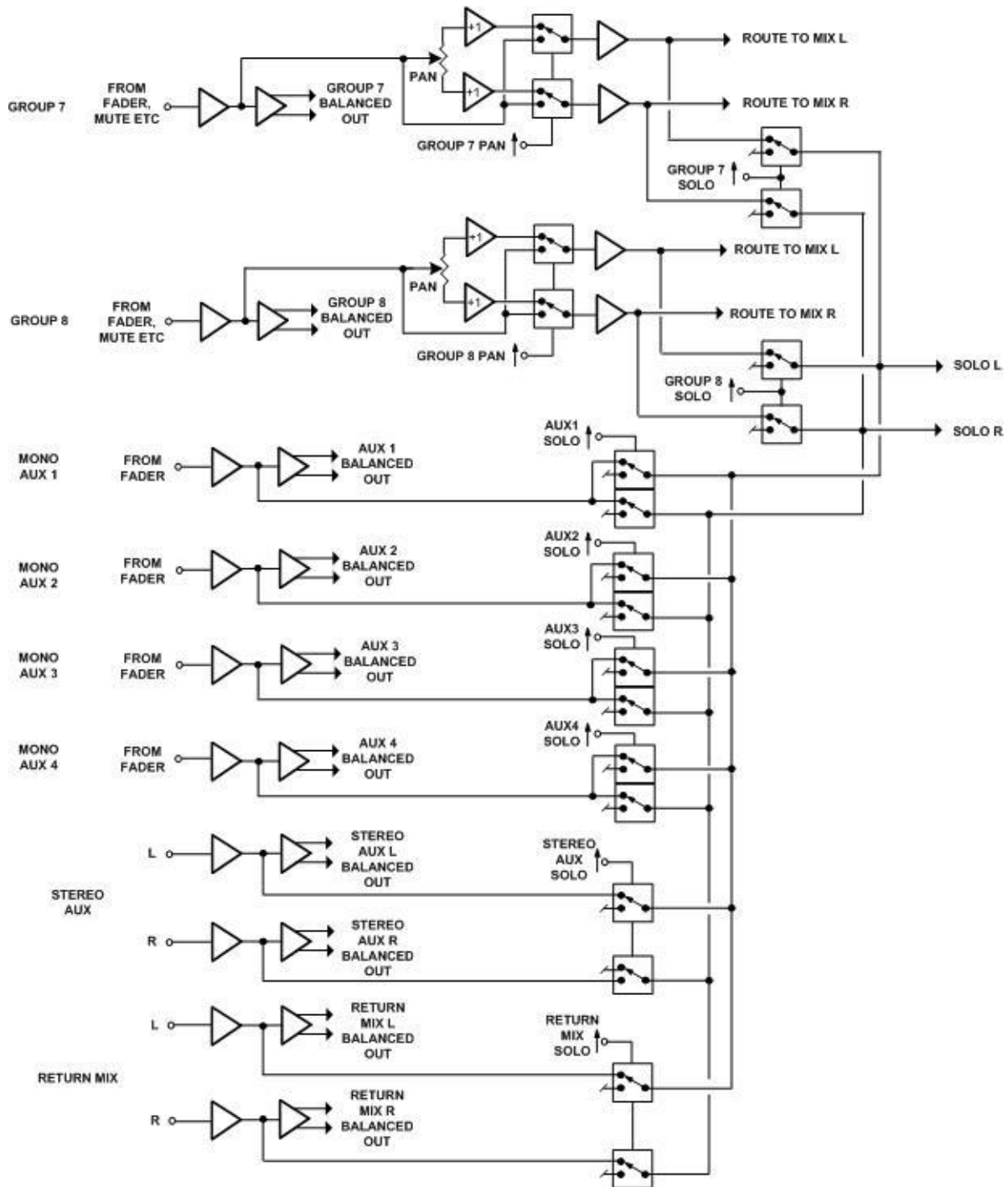

5.4 Solo in the Master Module

Figure 47 shows the solo path in the Master module. When solo is engaged from any solo source on the console the soloed signal will appear in the front monitor outputs. The main stereo mix and any external inputs being monitored are removed. Note that in solo the Mono, Mute (master and individual L-R), and alternate front speaker functions remain available.

- When Surround mode is engaged, solo operation is prevented

Figure 47: MASTER MODULE SOLO

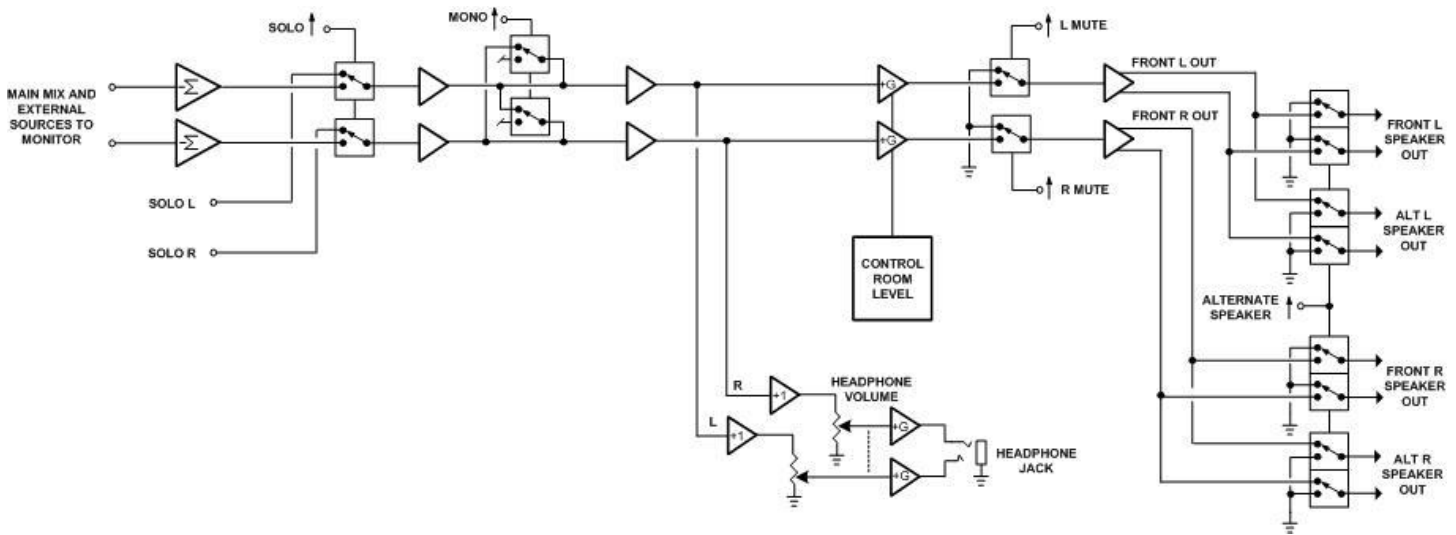

6.0 Monitor Inline Mode

Monitor inline signal flow in a mixing console was originally created at Harrison (by Dave Harrison himself in fact) in the tape recorder era to provide a method of simultaneous recording and monitoring in an enhanced channel strip. This innovation is carried over into the 32Classic.

Monitor inline mode is a splitting of the normal (mixing) signal flow path in the channel strip to optimize for recording as opposed to mixing. The channel source feeds the recording device while buses and main mix are fed by playback monitoring from the recording device. Thus, 2 distinct signal paths exist, the recording path and the monitoring path.

6.1 The Channel Strip in Monitor Inline Mode

The 2 signal paths in Monitor Inline mode are illustrated in [Figure 48](#) which shows the channel signal flow as a repeat of [Figure 39](#). Nominally, the channel source feeds the recording device through the channel insert, EQ, filters and direct output, with Aux sends available to provide Cue mixes to the performers. Note that Aux sends are set to always be post-EQ and at the Direct output point in this mode. Playback/monitoring from the recording device feeds the Group buses and Main mix through the channel fader and panner.

An additional feature in the 32Classic is the ability to route the Playback source to the Stereo Aux. This is also provided in Mixdown mode and is ancillary to Monitor Inline mode, but provides additional flexibility for other operations.

Figure 48: CHANNEL STRIP IN MONITOR INLINE MODE

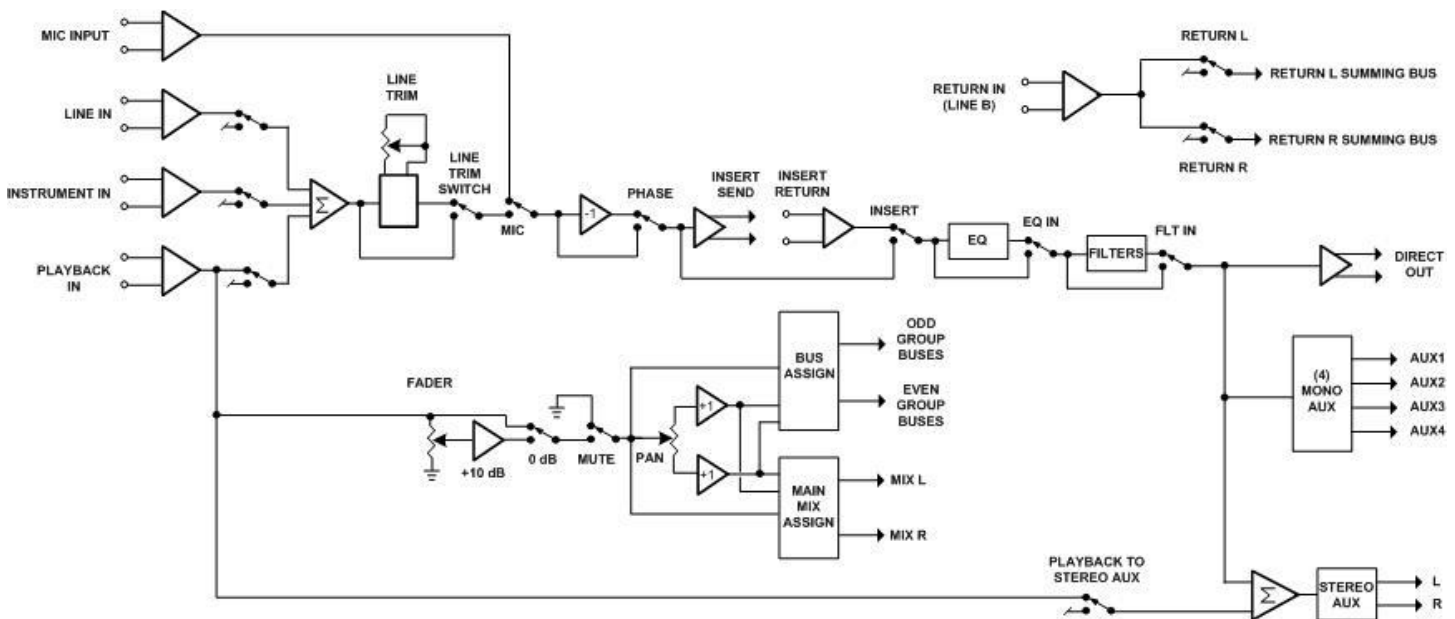

7.0 Mixdown With High Channel Count

The 32Classic console is capable of a large number of inputs in mixdown, as many as 96 inputs are available to create a final mix. This is made possible partly because of the ability to route the Stereo Aux to the main mix, and also the unique Return mixer path.

Figure 49 shows the Return and Aux master sections of Bus strip 7-8. Note their capability to route to the main stereo mix. The following sections will present a few ways this feature can be used for large mixes of up to 96 sources.

In all of the following examples the Return Mix provides 32 inputs to the final stereo mix. Though these inputs originate on each channel strip, they route directly to the Return mix buses without individual level control and only the master L-R level controls shown in Figure 49 are available locally. In all cases it is assumed that the sub-mix on the Return bus will be built external to the console at the signal source, whether another console, outboard gear, or DAW.

Figure 49: RETURN AND STEREO AUX MASTERS MIX ROUTING

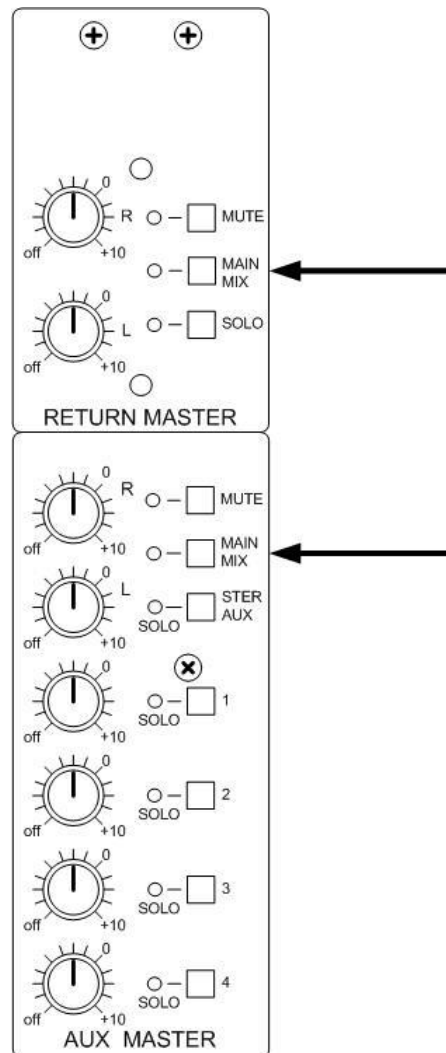

7.1 96 Channel Mix with Channel Strips in Mixdown Mode

Figure 50 shows the simplest but least flexible way to mix 96 sources. The 32 channel strips are in mixdown mode in this example. In this method each channel's Line and Playback inputs are summed at the channel strip input and share insert, EQ, filters, fader and panning to the stereo mix bus. Mix level setting and other individual processing must be done at the sources, typically a line level analog source at the Line In, and a DAW channel source via Dante at the Playback input. The remaining 32 inputs come from the Return input on each channel strip, which connect directly to the main L-R mix. Again, mix level setting and other channel processing must be done at the Return input sources for each channel strip. Only the master level control on the Bus 7-8 module is available in this path, and controls the overall level of the Return inputs' sum to the main mix.

Figure 50: 96 INPUT MIXDOWN - METHOD 1

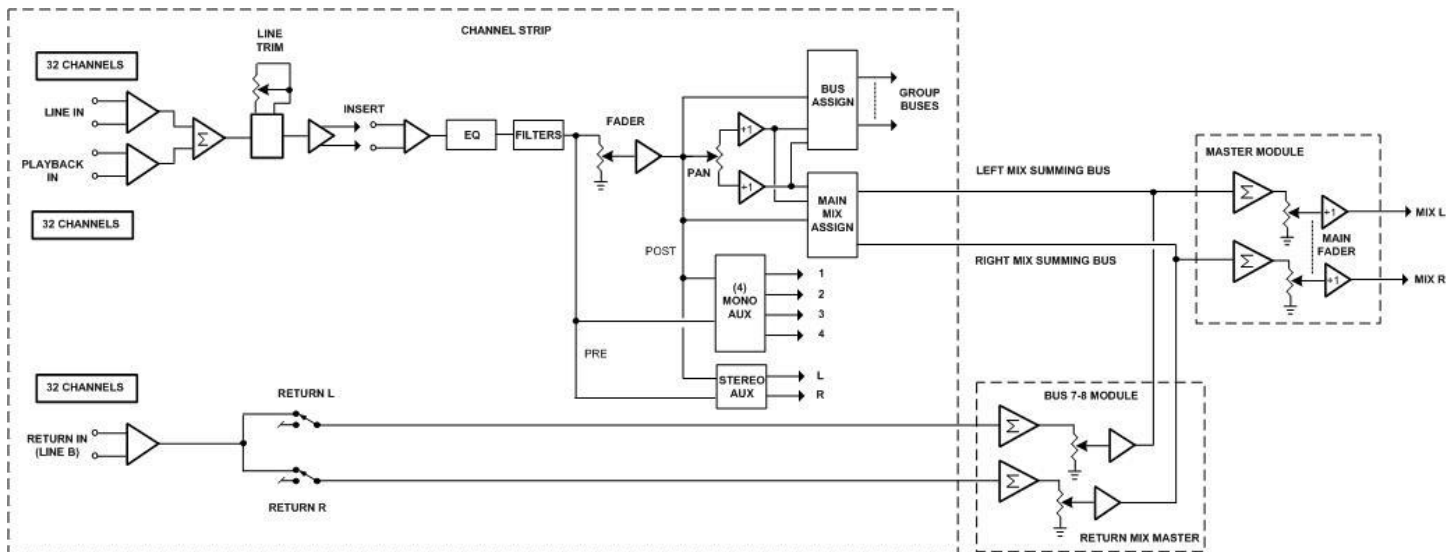
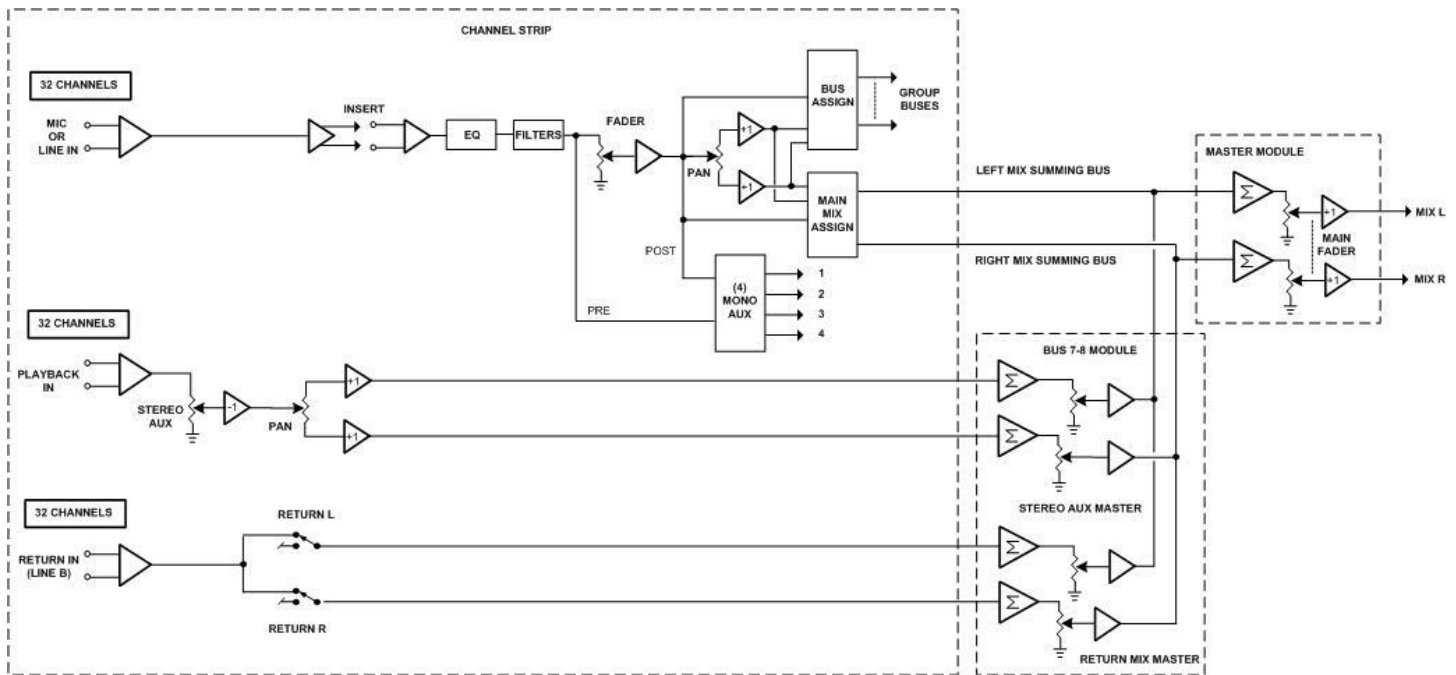

Figure 51 shows another possible setup for a 96 input mix with the 32 channel strips in mixdown mode. Channel Mic or Line inputs pass through the channel strip signal path conventionally, through insert -> EQ -> filters -> fader -> pan to the main stereo mix. Playback from the Dante is routed through the Stereo Aux send which provides individual Level and Pan control, however any EQ or other signal processing must be done at the source. Finally as in the previous example the Return mix input feeds the Main mix directly, and individual level control to the mix, EQ and any other signal processing must be done at the Return input sources for each channel strip.

Figure 51: 96 INPUT MIXDOWN - METHOD 2



7.2 96 Channel Mix with Channel Strips in Monitor Inline Mode

Figure 52 shows one way to mix 96 sources with the 32 channel strips in Monitor Inline mode. This method is similar to the example in Figure 51 except that the channel signal path with EQ and filters uses the Stereo Aux send to feed the main L-R mix. The Playback path from Dante uses the fader -> pan -> bus assign path. This method might be useful when the Playback input needs to also feed the Group buses or when it is desired to have the Playback input on the channel faders.

Note that the 4 mono Aux sends are hard set to be post EQ-filters when the channel strip is in monitor inline mode.

Figure 52: 96 INPUT MIXDOWN - METHOD 3

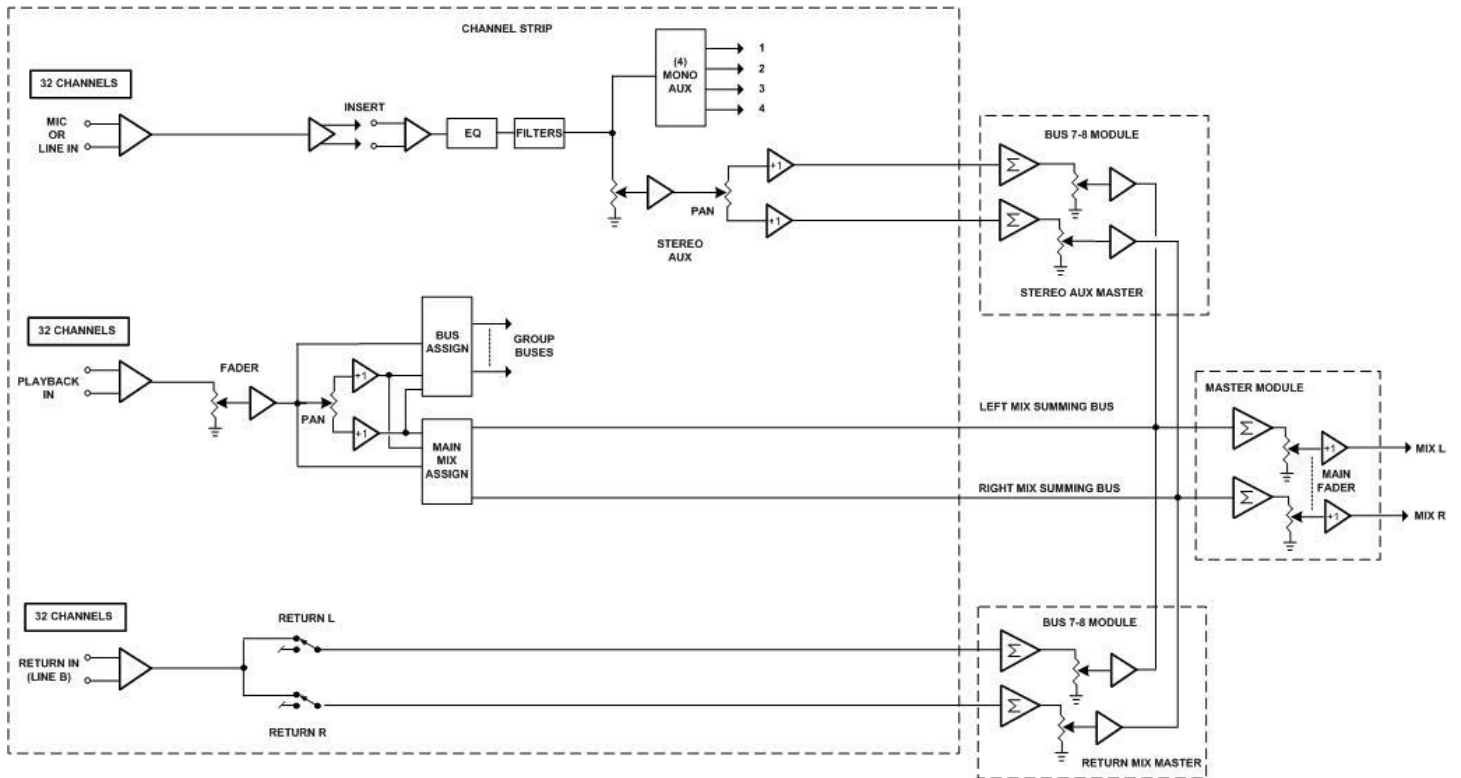

8.0 Specifications

Analog Specifications

Microphone Preamp:

Minimum Gain – 20 dB
Maximum Gain – 70 dB

Input Impedance – 5.8K
Input Impedance Pad In – 1.3K

Maximum Input Level No Pad - +4 dBu
Maximum Input Level With Pad - +24 dBu

THD 50 dB Gain - < 0.01%

Frequency Response 20 Hz – 20 KHz +/- 0.25 dB

Ein < -129 dBu

Line Level Inputs:

Input Impedance – 10K

Line Trim - +/- 9.5 dB

Maximum Input Level - +24 dBu

THD +4dBu Line Input To Stereo Mix Output < 0.01%

Frequency Response 20 Hz – 20 KHz +/- 0.25 dB

Line Level Outputs:

Maximum Output Level - +24 dBu

Output Impedance – 30 Ohms

Output Impedance Main Mix Output With Transformers Activated – 75 Ohms

Dante/Digital Specifications

Networking Format:

- 64 Channel Dante over Ethernet (1G Ethernet preferred)

Number of implemented channels:

- 32 In, 32 Out

Number of A/D Channels:

- 32

Number of D/A Channels:

- 32

Input/Output Levels:

- standard +4dBu line level, balanced

I/O Connections:

- (8) Female DB25 connectors to Tascam/AES59 specification

Supported Sample Rates:

- 32K, 44.1K, 48K, 88.2K, 96K

Word Clocking Options:

- Dante network Slave, Dante network Master (internal), External TTL Wordclock

External Wordclock Connection:

- 75 Ohm BNC connector, not terminated

Configuration and Routing Control:

- using Dante Controller application

Performance Specifications, Analog to Digital:

- Maximum input Level for full scale 0 dBFS output: +24 dBu
- Total THD+Noise @ +4 dBu input < 0.01%

- Noise floor (digital) with zero input: < -96 dBFS 48KHz and 96KHz
- Frequency Response 20 Hz – 20 KHz +/- 0.25 dB

Performance Specifications, Digital to Analog:

- Maximum output Level for full fcale 0 dBFS input: +24 dBu
- Total THD+Noise @ +4 dBu output < 0.01%
- Noise floor (analog) with 0 dBFS input: < -100 dBu at 48KHz and 96KHz
- Frequency Response 20 Hz – 20 KHz +/- 0.25 Db

General Specifications

- Frame profile dimensions

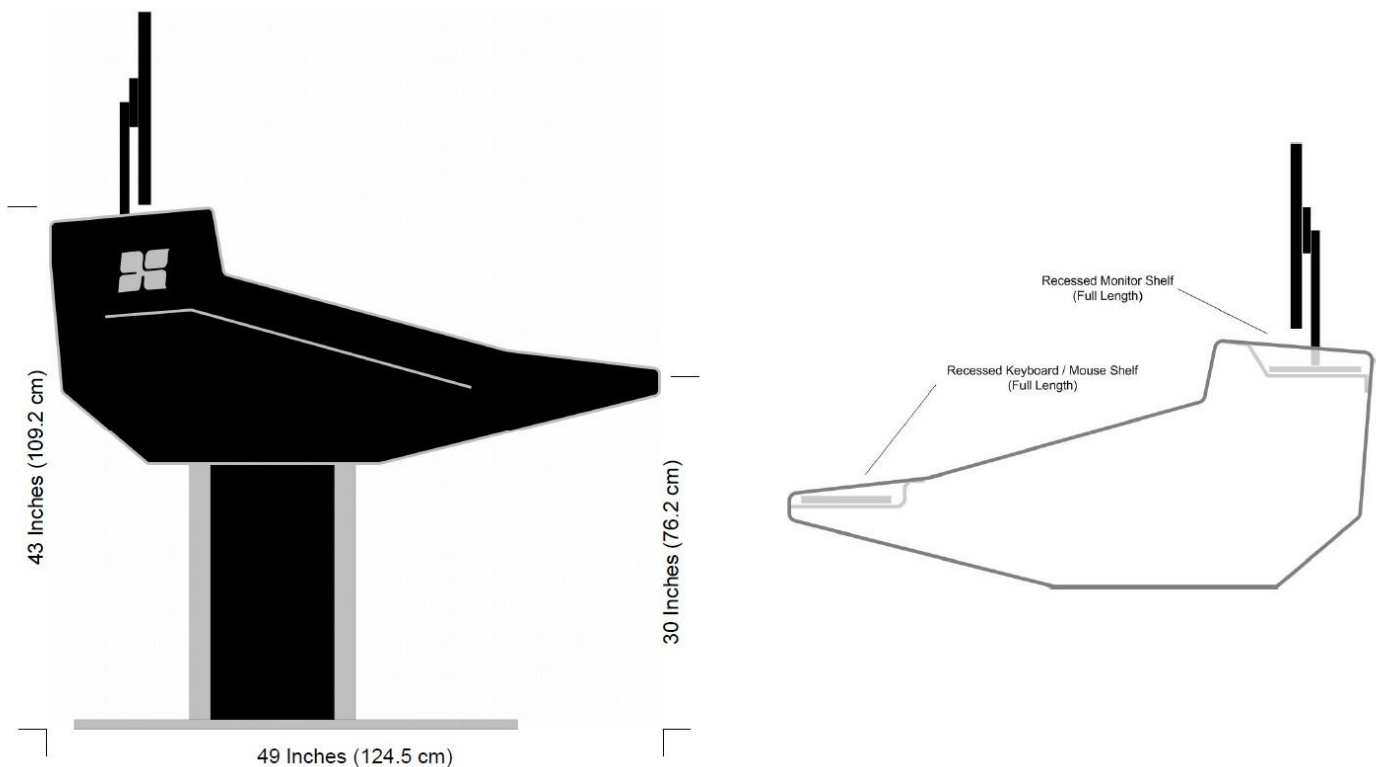

- Length: 80.55" (204.6 cm)
- Weight 450lbs (204 kg)
- 100-240 Vac, 50/50 Hz, 12.0-6.0 A
- Operating ambient temperature range 1°C to 30°C
- ACDC SMPS is 600W @ 12V (50A)
- Total Watts = 438.21, @75% efficiency = 584.28, Amps @ 120V = 4.869

9.0 Safety Notices

General Safety

- Please read and keep this document and adhere to all warnings and instructions.
- This electrical equipment should not be exposed to dust, water, or other liquids.
- Clean only with dry cloth or products compatible with electrical devices and never when the unit is powered.
- Do not operate near any heat sources, in direct sunlight or near naked flames.
- Do not place heavy objects on the unit.
- Only use attachments/accessories recommended by the manufacturer.
- Unplug this apparatus during lightning storms or when unused for long periods of time.
- Do NOT modify this unit, alterations may affect performance, safety and/or international compliance standards.
- The unit can only be serviced by qualified personnel – seek immediate service if the console has been exposed to water or if it ceases to operate normally.
- Harrison does not accept liability for damage caused by maintenance, repair or modification by unauthorized personnel.
- When using this apparatus either fix it into a standard 19" rack or place it on a secure level surface.
- If the unit is rack mounted, fit all rack screws. Rack shelves are recommended.
- Do not block any ventilation openings. Install in accordance with the manufacturer's instructions.
- Always allow free flow of air around the unit for cooling.
- Ensure that no strain is placed on any cables connected to this apparatus. Ensure that all such cables are not placed where they can be stepped on, pulled, or tripped over.

Power Safety

- This equipment is supplied with mains lead however if you wish to use a mains cables of your choice refer to the following information: • Refer to the rating label on rear of the unit and always use a suitable mains cord.
- The unit should ALWAYS be earthed.
- Please use-compliant 60320 C13 TYPE SOCKET. When connecting to supply outlets ensure that appropriate sized conductors and plugs are used to suit local electrical requirements.
- Maximum cord length should be 4.5m(15').
- The cord should bear the approval mark of the country in which it is to be used. Additionally:
- The appliance coupler is used as the disconnect device, ensure that it is connected to an unobstructed wall outlet.
- Connect only to an AC power source that contains a protective earthing (PE) conductor.
- Only connect units to single phase supplies with the neutral conductor at earth potential. ATTENTION! This product must always be earthed. CAUTION! No user-serviceable parts inside. In the event of damage to the unit contact Solid State Logic. Service or repair must be done by qualified service personnel only.

Additionally:

- The appliance coupler is used as the disconnect device, ensure that it is connected to an unobstructed wall outlet.
- Connect only to an AC power source that contains a protective earthing (PE) conductor.
- Only connect units to single phase supplies with the neutral conductor at earth potential



ATTENTION! This product must always be earthed.

CAUTION! No user-serviceable parts inside. In the event of damage to the unit contact Solid State Logic. Service or repair must be done by qualified service personnel only.



This product complies with the following United Kingdom Legislation:

UK Electrical Equipment (Safety) Regulations 2016 (SI 2016/1101)

UK Electromagnetic Compatibility Regulations 2016 (SI 2016/1091).

The Eco-design requirements for Energy related products (ErP) 2009/125/EC.

The Restriction of the use of certain Hazardous Substances in Electrical and Electronic Equipment (RoHS2) Regulations 2012 (SI 2012/3032).



This product complies with the following European Union Harmonisation Legislation:

EU Low Voltage directive (LVD) 2014/35/EU,

EU Electromagnetic Compatibility directive (EMC) 2014/30/EU.

The Eco-design requirements for Energy related products (ErP) 2009/125/EC.

The Restriction of the use of certain Hazardous Substances in Electrical and Electronic Equipment Directive (RoHS2) 2011/65/EU.



Instructions for disposal of WEEE by users in the European Union

The symbol shown here, which is on the product or on its packaging, indicates that this product must not be disposed of with other waste. Instead, it is the user's responsibility to dispose of their waste equipment by handing it over to a designated collection point for recycling of waste electrical and electronic equipment. The separate collection and recycling of your waste equipment at the time of disposal will help to conserve natural resources and ensure that it is recycled in a manner that protects human health and the environment. For more information about where you can drop off your waste equipment for recycling, please contact your local city office, your household waste disposal service or where you purchased the product.

FCC Certification

- This device complies with part 15 of the FCC Rules. Operation is subject to the following two conditions: (1) This device may not cause harmful interference, and (2) this device must accept any interference received, including interference that may cause undesired operation.

For the user:

- Do not modify this unit! This product, when installed as indicated in the instructions contained in the installation manual, meets FCC requirements.
- Important: This product satisfies FCC regulations when high quality shielded cables are used to connect with other equipment. Failure to use high quality shielded cables or to follow the installation instructions may cause electromagnetic interference with appliances such as radios and televisions and will void your FCC authorization to use this product in the USA.
- This equipment has been tested and found to comply with the limits for a Class A digital device, pursuant to part 15 of the FCC Rules. These limits are designed to provide reasonable protection against harmful interference when the equipment is operated in a commercial environment. This equipment generates, uses, and can radiate radio frequency energy and, if not installed and used in accordance with the instruction manual, may cause harmful interference to radio communications. Operation of this equipment in a residential area is likely to cause harmful interference in which case the user will be required to correct the interference at his own expense.

Industry Canada Compliance

This Class A digital apparatus complies with Canadian ICES-003. Cet appareil numérique de la classe A est conforme à la norme NMB-003 du Canada.

Electromagnetic Compatibility

BS EN 55032:2015, Class A. BS EN 55035:2017.

WARNING: The audio input/output ports are screened cable ports and any connections to them should be made using braid screened cable and metal connector shells to provide a low impedance connection between the cable screen and the device.

Electrical Safety

IEC 62368-1:2018

BS EN IEC 62368-1:2020+A11:2020

CSA CAN/CSA-C22.2 No. 62368-1 3rd Ed.

UL 62368-1 3rd Ed.



WARNING: Cancer and Reproductive Harm - www.P65Warnings.ca.gov

Environmental

Temperature: Operating: +1 to 30 degrees Celsius. Storage: -20 to 50 degrees Celsius.

Further information

For additional information, product downloads, knowledge base and technical support visit the www.harrisonaudio.com.

ECO Statement

80% recycled cardboard will be used in the packaging design as a minimum.

100% recyclable packaging.

No polyfoam will be used in the packaging design. Pulp based packaging inserts will be used as an alternative.

Packaging will be optimized to reduce its volume and weight and packaging materials will be easily separated for recycling.

Where allowed, user documentation will be available for download only. Only mandatory safety information will be provided in hard copy.

80% post-consumer recycled aluminum will be used in the front panel design.

Given their major contribution to the product's carbon footprint, PCBs will be optimized to minimize board area, layer count and to limit wastage.

Low power operation will be a focus throughout the design.

To promote switching off the unit after use, the power switch will be located on the front panel to maintain accessibility when rack mounted.

Component selection and lifetime testing will be based on a minimum life expectancy of 10 years. The design will support user servicing allowing individual connectors, pots, switches, and other parts to be replaced easily to ensure economically viable repair by a competent user or local repair center extending the product's service life.

The unit's construction method will allow easy dis-assembly supporting separating and recycling core components when the product reaches its end of life.

References

1. Pty Ltd, Dante Brooklyn II Module Technical Datasheet, v2.7, 4 May 2015, Document # AUD-TDS-BROOKLYNII-2.7.pdf

2. Dante Virtual Soundcard manual, document version v2.1 for Dante Virtual Soundcard v3.2. Pty Ltd, 23 May 2013
3. Dante Controller User Guide, AUD-MAN-DanteController-3.5.x-v1.6.
4. White Paper, Digital_Audio_Networking_Just_Got_Easy, Pty Ltd, document # 2.0US-09A09, 2009

10.0 Patch Bay Examples

32 Channel Example (Patch Bay NOT Included)

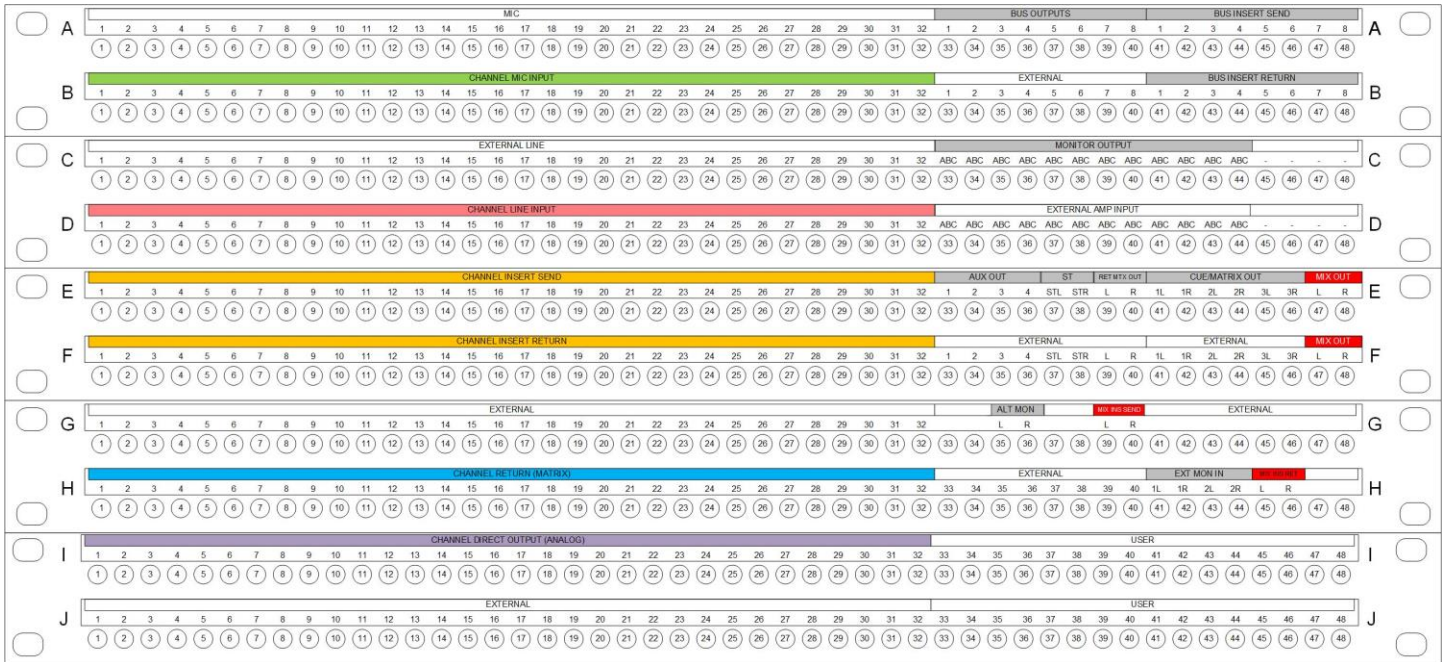

48 Channel Example (Patch Bay NOT Included)

